

UMIC: Ultra High-Speed Mobile Information and Communication

Universal Mobile Access to Information and Communication

RWTH Aachen University

Final Report for Cluster of Excellence EXC 89

Excellence Initiative by the German Federal and State Governments

01.11.2006 – 31.10.2014

Deutsche
Forschungsgemeinschaft



**Excellence Initiative by the German Federal and State Governments
to Promote Science and Research
at German Universities**

**Final Report
for a
Cluster of Excellence**

Cluster of Excellence

EXC 89

**Ultra High-Speed Mobile
Information and Communication (UMIC)**

(Universal Mobile Access to
Information and Communication)

RWTH Aachen University

First Funding Period

1 November 2006 – 31 October 2012

Second Funding Period

1 November 2012 – 31 October 2014

Final Report for a Cluster of Excellence

Ultra High-Speed Mobile
Information and Communication (UMIC)

Host university:

RWTH Aachen University

Rector of RWTH Aachen University:

Coordinator of the cluster of excellence:

Univ.-Prof. Dr.-Ing. Ernst M. Schmachtenberg

Univ.-Prof. Dr.-Ing. Gerd Ascheid

Contents

1	General Information	1
1.1	Summary	1
1.2	Key data	3
1.2.1	Host, speaker and other participating institutions	3
1.2.2	Overview of the cluster's structure	3
2	Research	5
2.1	Overview	5
2.2	Research areas and their interconnection	7
2.2.1	Research area A (RA-A): Wireless transport platform (cognitive radio networks and systems)	7
2.2.2	Research area B (RA-B): Application and services (ubiquitous information mobility)	19
2.2.3	Research area C (RA-C): RF subsystems & SoC design (flexible terminal technology)	34
2.2.4	Research area D (RA-D): Cross disciplinary methods and tools	47
2.2.5	Impact of UMIC after the funding period	58
3	People	61
3.1	Impact of the centre on academic positions	61
3.2	Promotion of early career researchers	62
3.3	Promotion of gender equality	64
4	Structures	67
4.1	Organisation and management of the centre	67
4.1.1	Steering committee and management	67
4.1.2	Advisory board	68
4.1.3	Gender appointee	69
4.1.4	Centre office	69
4.1.5	Structural and administrative integration into the host university	69
4.1.6	Public outreach, transfer activities	70
4.2	Relationship between the centre, the host university and the participating partners	71
4.2.1	Role of the centre within the host university	71
4.2.2	Relationship to participating partners	72
4.3	Sustainability	73
4.3.1	Measures for sustainability	73
4.3.2	Sustainable behavioural impact of the UMIC research centre	73
4.3.3	Impact on the research profile	75

5	Overview of the Centre's Resources	77
5.1	Resources.....	77
5.1.1	Staff.....	77
5.1.2	Infrastructure	78
6	Comments to the DFG	79
7	Appendix A	1
7.1	Most important publications of the centre	1
7.1.1	Journal publications	1
7.1.2	Conference publications	5
7.2	Additional achievements	6
7.3	PIs and other participating researchers	9
7.3.1	Principal investigators.....	9
7.3.2	Junior professors and junior research group leaders	10
7.3.3	Participating researchers at RWTH Aachen University	10
7.3.4	Participating researchers at other universities.....	11
7.4	Doctoral researchers	12

1 General Information

1.1 Summary

The initial goal of the UMIC cluster was to enable future *Ultra High-Speed Mobile Information and Communication*, with the main vision of broadband wireless internet access at reasonable access costs triggering the next wave of economic and innovation growth. Today it is indeed the low cost access, predominantly in the form of flat data rates, which drives the exponentially increasing mobile Internet access. This has led to a strong cost pressure on operators and equipment providers. Researching technologies that address these problems has thus been the right approach. Over time mobile internet access grew rapidly. UMIC reacted to this with a shift in the focus to *Universal Mobile Access to Information and Communication*, thus putting more emphasis on the user perspective with technologies supporting universal mobile access.

A major differentiator of the research centre to competitors and the usual chair based systems in faculties is its ability to closely collaborate, addressing particular problem domains on a broader scale. In UMIC three interdisciplinary flagship projects emerged over the course of the collaboration: *LocalizeMe*, addressing application topics, *Cognitive Radios and Networks*, addressing flexible and efficient use of the wireless communication resources, and *Nucleus*, addressing platforms and design methodology for flexible (mobile) terminals. Research in the UMIC centre produced substantial scientific results documented by, e.g. more than 1,000 peer-reviewed journal and conference papers, by extensive technology transfer to industry partners and via start-up companies and by one Leibniz Prize and three ERC Grants received during the UMIC funding period.

Further, the UMIC research cluster has led to cultural and structural changes in the involved departments of RWTH Aachen University. Most notably, it has successfully introduced a structured career path for junior researchers based on Junior Professor positions (assistant professorship). Out of 6 established junior professorships 3 have got tenure in Aachen, 2 in other international top universities, and one more is still in the tenure track. This shows the high quality of the candidates the UMIC was able to attract. UMIC gender equality promotion activities contributed significantly to a development where both Computer Science and Electrical Engineering departments increased the percentage of female researchers in post study career stages (i.e. Doctoral degrees and Professors) to a balance with the percentage of female students. Last but not least UMIC has been intellectual home for 176 doctoral researcher of which 97 have already successfully defended their doctoral thesis work.

The UMIC research centre building, the new research groups and the five labs with state-of-the-art equipment teams established through UMIC funding are the basis of sustained UMIC research. Moreover, UMIC research is a key component of the strategy of the Information and Communication Technology (ICT) profile area of RWTH Aachen University.

Zusammenfassung

Ziel des Exzellenzclusters UMIC war zunächst die Ermöglichung höchst-ratiger mobiler Information und Kommunikation (*Ultra High-Speed Mobile Information and Communication*, UMIC). Vision war, dass ein breitbandiger, drahtloser mobiler Internetzugang zu akzeptablen Zugangskosten die nächste Welle von Wirtschaftswachstum und Innovation treiben würde. Tatsächlich ist es heute der kostengünstige Zugang (z.B. durch „Flatrates“), der eine exponentiell ansteigende mobile Internetnutzung antreibt. Die Folge ist ein starker Kostendruck auf Mobilfunknetzbetreiber und Hersteller. Die Erforschung von Technologien, die diese Probleme adressieren, war daher der richtige Ansatz. Als der mobile Internetzugang stark anzuwachsen begann, reagierte das UMIC Forschungscluster mit einer Weiterentwicklung des Fokus zu universellem mobilem Zugang zu Information und Kommunikation (*Universal Mobile Access to Information and Communication*) und legte damit mehr Gewicht auch auf die Nutzersicht.

Ein wesentliches Unterscheidungsmerkmal des Forschungszentrums im Vergleich zu Konkurrenten und üblichen Lehrstuhl-basierten Strukturen in Fakultäten ist die engere Zusammenarbeit, durch die Forschungsprobleme aus einer viel breiteren Perspektive adressiert werden können. In UMIC sind so drei interdisziplinäre Flagship-Projekte entstanden: *LocalizeMe*, das Anwendungsthemen adressiert, *Cognitive Radios and Networks*, das die flexible und effiziente Nutzung der Ressourcen der Mobilkommunikation adressiert und *Nucleus*, das Plattformen und Designmethoden für flexible (mobile) Endgeräte adressiert. Die Forschung im UMIC Centre hat substantielle wissenschaftliche Resultate hervorgebracht, dokumentiert u.a. durch mehr als 1.000 Expertenbegutachtete Journal- und Konferenzbeiträge, durch extensiven Technologietransfer zu Industriepartnern und über Neugründungen sowie durch einen Leibniz-Preis und drei ERC-Grants die UMIC Forscher während der Förderzeit erhielten.

Darüber hinaus hat das UMIC zu Änderungen in Kultur und Struktur der beteiligten Fachbereiche geführt. Insbesondere wurde sehr erfolgreich ein strukturierter Karrierepfad für Nachwuchsforscher eingeführt. Von den 6 neuberufenen Juniorprofessuren erhielten fünf bereits entfristete Professuren an der RWTH Aachen bzw. an internationalen Universitäten, die sechste befindet sich noch in der Qualifizierung vorhandene Dauerstelle. Das belegt die hohe Qualität der ausgewählten Nachwuchsforscher. Die Gleichstellungsaktivitäten von UMIC haben signifikant dazu beigetragen, dass der Prozentsatz der Wissenschaftlerinnen in den höheren Karrierestufen (Promotion, Professur) auf den Prozentsatz von Studentinnen angewachsen ist. Nicht zuletzt war UMIC die wissenschaftliche Heimat für 176 Doktoranden und Doktorandinnen von denen 97 bereits erfolgreich promoviert haben.

Das UMIC Forschungszentrum, sowie die durch UMIC Finanzierung neu eingerichteten Professuren und fünf Labore mit modernster Ausrüstung sind die Basis für eine dauerhafte UMIC Forschung. Nicht zuletzt ist UMIC eine Schlüsselkomponente in der Strategie des Profilbereichs Informations- und Kommunikationstechnik (ICT) der RWTH Aachen.

1.2 Key data

1.2.1 Host, speaker and other participating institutions

Table 1-1: Participating institutions (complete funding period)

Host university	Location
<i>RWTH Aachen University</i>	Aachen

1.2.2 Overview of the cluster's structure

In the main funding phase (i.e. the first funding phase) the cluster had five units, four research areas and a central management unit which also included education, dissemination and training led by Prof. Dr. rer. nat. Rudolf Mathar. These units are listed in Table 1-2.

Table 1-2: Structure of the cluster in the main funding phase

Unit (research area, etc.)	Title	Academic discipline and research direction	Project leader, institute (All institutes are located at RWTH Aachen University)
<i>A</i>	<i>Wireless Transport Platform</i>	<i>Electrical Engineering (EE)</i>	Prof. Dr.-Ing. Bernhard Walke Communication Networks (11/2006-12/2007) Prof. Petri Mähönen, PhD Networked Systems (since 01/2008)
<i>B</i>	<i>Application and Services</i>	<i>Computer Science (CS)</i>	Prof. Dr. rer. pol. Mathias Jarke Information Systems and Database Technology
<i>C</i>	<i>RF Subsystems & SoC Design</i>	<i>EE, CS</i>	Prof. Dr.-Ing. Tobias Noll Electrical Engineering and Computer Systems
<i>D</i>	<i>Cross Disciplinary Methods and Tools</i>	<i>CS, EE</i>	Prof. Dr.-Ing. Stefan Kowalewski, Software for Embedded Systems
<i>Z</i>	<i>Central Management</i>		Prof. Dr.-Ing. Gerd Ascheid, Integrated Signal Processing Systems

As originally proposed, a transition in the project lead was implemented during the first funding phase: Due to the retirement of Prof. Bernhard Walke, responsibility for research area A was transferred to Prof. Petri Mähönen. Further, due to the retirement of Prof. Otto Spaniol, new Vice Speaker of the cluster became Prof. Matthias Jarke in 2010. As his successor as project leader of research area B (RA-B) Prof. Leif Kobbelt was nominated. In addition, Prof. Rainer Leupers became project leader of research area C (RA-C).

Table 1-3: Structure of the cluster at the end of the funding

	Unit (research area, etc.)	Title	Academic disci- pline and re- search direction	Project leader, institute (All institutes are located at RWTH Aachen University)
	<i>A</i>	<i>Cognitive Radio Networks & Systems</i>	<i>Electrical Engi- neering (EE)</i>	Prof. Petri Mähönen, PhD Networked Systems
	<i>B</i>	<i>Ubiquitous Information Mobility</i>	<i>Computer Sci- ence (CS)</i>	Prof. Dr. rer.nat. Leif Kobbelt Computer Graphics and Multimedia
	<i>C</i>	<i>Flexible Terminal Technology</i>	<i>EE, CS</i>	Prof. Dr. rer.nat. Rainer Leupers, Software for Systems on Silicon
	<i>D</i>	<i>Cross Disciplinary Methods and Tools</i>	<i>CS, EE</i>	Prof. Dr.-Ing. Stefan Kowalewski, Software for Embedded Systems
	<i>Z</i>	<i>Central Management</i>		Prof. Dr.-Ing. Gerd Ascheid, Integrated Signal Processing Systems

2 Research

2.1 Overview

The main vision of UMIC for the first funding phase was that broadband wireless Internet access at reasonable access costs could trigger the next wave of economic and innovation growth, comparable to the wave triggered by introduction of fixed line internet access and cellular telephony. This vision was developed in preparation of the proposal for this cluster in the year 2005. Taking into account that earlier introduction of UMTS was not a commercial success and, therefore, there was a wide spread scepticism about mobile data use cases, it was a risky and courageous research vision at that time. With the introduction of the iPhone and new business concepts in 2007 a mobile internet wave was started which remarkably verified our vision.

The guideline for **research** of the 1st phase was to study specific technologies and methods that could lead to significant increase in the perceived quality of experience for users. The UMIC cluster has provided a significant leverage effect to the research programmes that existed previously in the separate chairs of the principal investigators. The common goals, increased collaboration in an interdisciplinary manner, and better testbeds and equipment, combined with the recruitment of young talented graduate students and junior group leaders have enabled us to make a difference where the end result is larger than the sum of its individual parts. The research output of the UMIC cluster has become comparable to leading international competitors, and, most notably, the publication culture – both in quality and quantity – has developed considerably in all participating institutions over the funding periods.

Most of the major goals of our research have been achieved. Research is not without risks so we have been more successful in some fields than in others. One of the interdisciplinary highlights (“flagships”) in our research programme has been the work on architecture, algorithms, and implementation of modularized transceivers, the so called **Nucleus concept**. It has the potential to become a unique and also commercially valuable basis for future multi-core implementations of software defined radios (SDR) and cognitive radios (CR). This work has received international recognition and we have prototyped tools, architecture and key components, including prototyping of a Nucleus based transceiver in an emulated environment, testing of basic features in an experimental multi-core platform of a major silicon manufacturer, design, production and measurement of a sphere decoder accelerator ASIC (in cooperation with ETH Zurich) and an iterative MIMO demapper and decoder ASIC (in cooperation with EPF Lausanne), as well as design and implementation of a decomposable MAC-framework. Beyond the research results, parts of the technology have been transferred to application. Although the Nucleus concept emerged from

one research area, it already integrated work from other research areas in the main funding phase and is one of the basis for sustaining future collaboration.

Another extremely successful research line has been our work on **cognitive radio** (networks) that grew from a sub-area topic to a flagship research programme. The competence that has been built in this domain would not have been possible without the interdisciplinary links, critical mass, and equipment provided by UMIC. The work has led, for example, to a number of world-class measurement campaigns that has been conducted in Europe, to development of new spectrum occupancy modelling methods, and to development and early prototyping of the highly innovative cognitive resource management concepts for future wireless networks and cognitive radios. Like Nucleus, this programme has also strongly integrated research from both EE and CS domains. The work fuelled collaboration between CS and EE groups, e.g. on novel resource allocation algorithms to enable efficient CR operations and in the development of the “Cognitive Resource Manager (CRM)” framework, which spans the four lower OSI layers and exhibits many difficult problems that are also known in the context of real-time applications and operating systems. As the work progressed in UMIC we gained increased visibility not only in the research community but also among manufacturers, operators, and in standardisation fora. This has led to the positive feedback loop, where we have gained through technology transfer also feedback from real-world challenges for our future research.

The third flagship research initiative “Localize Me“ emerged in the context of Research Area B where concepts from Computer Vision, Computer Graphics and Human-Computer-Interaction have been combined and extended such that innovative solutions for the fundamental tasks in mobile multimedia applications could be developed. Beside new remote rendering techniques (where image synthesis computations are partially delegated from the mobile device to a remote server) and mobile user interfaces (where, e.g. multiple mobile devices can be combined into a synchronized multi-display) the major focus in this flagship project was on algorithms to recover the pose of a mobile device from an image taken with the built-in camera by efficiently detecting and matching image features. In a series of high impact papers which appeared at the major international conferences in this field [ICCV 09&11, ECCV 12&14], we developed new techniques which significantly extended the state of the art in terms of localization precision and speed as well as in the size of the environment that can be handled (i.e. from “room-scale” to “city-scale”).

The UMIC research concept has been strong and, as will be detailed subsequently, we have reached in the domains of our specific flagship projects a clear international top level, and overall achieved in almost all sub-areas good international level in our research. Thus are convinced that we have comfortably reached our research concept goals set for the UMIC cluster.

2.2 Research areas and their interconnection

2.2.1 Research area A (RA-A): Wireless transport platform (cognitive radio networks and systems)

2.2.1.1 Introduction

The main research target of RA-A was to enable universal wide-area access for broadband wireless services in a cost efficient manner. Cognitive Radio Networks became gradually and in organic fashion one of the flagship research programmes of UMIC, and during the last half of the funding period formed a significant part of UMIC research success across research areas. The wireless transport platform, initial research goal of RA-A, became a research topic seen in the context of cognitive radio networks. This has led to strong cooperation and has shown strong synergies with the flexible transceiver research of RA-C, thus linking implementation and algorithmic research.

2.2.1.2 Major research achievements: cognitive radio technology aspects

The main goal of the cognitive radio (CR) technology programme was originally to consider some limited architectural aspects of cognitive radios. However, our rapid success, thanks to close cooperation between several participating institutes, made cognitive radio technologies one of the flag-ship research domains in RA-A for the last three years of the funding period. We highlight in the following some of the key aspects of our research accomplishments.

Large-Scale Spectrum Measurement Campaigns and Spectrum Use Modelling & Topology Aware Network Analysis and Protocols: UMIC has conducted a number of large-scale spectrum measurement campaigns in several European countries to study the real spectrum use statistics and patterns. As a part of this work the novel measurement platform and methodology was developed and established in order to enable high precision measurements. These measurements represent the state of the art in the field both in quantity and quality. For post-processing of the data UMIC researchers developed novel methods to analyse spectrum data in a spatiotemporal manner applying spatial statistics and methods from statistical physics. The spatial statistics based models have been among the very first that have been published in this field. A large part of the measurement data has also been made publicly and freely available to other research groups that led to significantly increased visibility of UMIC and RWTH. This also enhanced cooperation with external partners and generated new joint projects, e.g. in the context of European Union research programs. *The academic and industry groups from at least 20 different countries have so far downloaded our publicly available data.*

Moreover, the close cooperation of the UMIC research cluster with one of the major operators in Germany enabled us to have access to extra information to correlate data from operational network with our measurements and theoretical work. The UMIC funding has been the primary enabler for all this work. Especially the UMIC funding and support for equipment, deployment of devices, and hiring of some of the key researchers has been crucial. The results, and subsequent extra projects, could not have been generated without the excellence cluster. The spectrum measurement platform and its software was designed and integrated by UMIC researchers, and we are currently deploying already the second-generation measurement systems in our campaigns. Already the developed first generation spectrum measurement capability was quite unique for any university working in this field, and provided a strong competitive advantage for UMIC groups to stay a step ahead of competitors also in the future. Moreover, the UMIC funding has enabled theory oriented students to work in focused manner towards analysing the data and developing novel spectrum use modes. Some of the work has been published in top conferences and international journals. We have been also one of the first groups to estimate the real available TVWS (TV White Space) availability in Europe and have developed the first terrain model enhanced methodology for such estimation tasks. In Figure 2-1 we present partially recent results from our European TV White

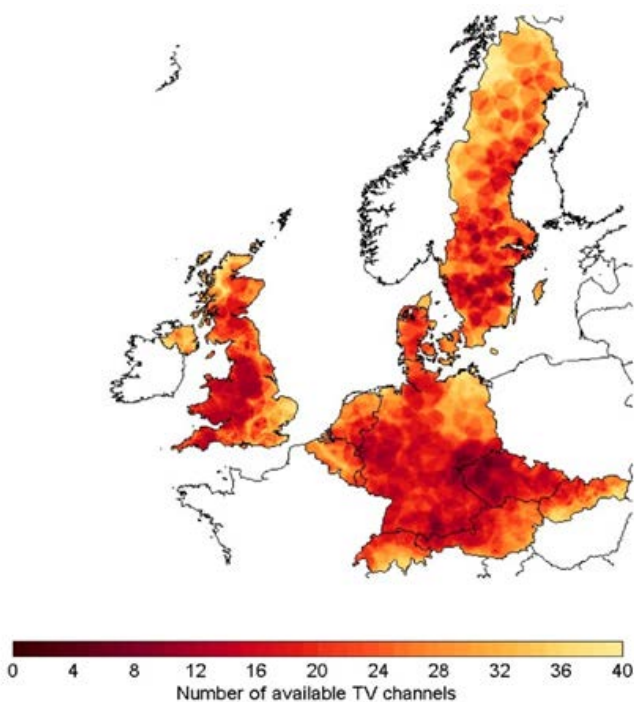

Figure 2-1: European TV White Space Analysis

Space analysis done for 11 different countries under a realistic model for secondary use and propagation. The results show that although the availability of white space in Europe is good it is somewhat reduced compared to the situation in the USA, and that different regulatory domains need to be considered very carefully. [vandeBeek2011; Wellens 2008a, 2008b, 2009a, 2009b, 2010; Riihijärvi2011; Palaios2013a]. Our subsequent work was also making high-precision measurements in large-cities and correlating the data against socio-economical conditions to better understand the use of mobile networks and spectrum occupancy [Palaios2013b, 2014a,

2014b]. TVWS work led also to highly cited work on studying practical applicability of different access methods, such as OFDMA or CMA, as secondary user system. In this context a new software tool was developed to assess the feasibility of secondary systems as cognitive radios –

the tool was demonstrated not only in the conferences but also to several regulators most notably to technical management of FCC in the USA [Achtzehn2015; Simic2012; Achtzehn2014].

In spatial statistics analysis one of the highlights has been our work on characterizing the distribution of node locations in wireless networks, and the development of performance estimators for capacity, power consumption, and deployment costs of networks under different spatial structures. One highlight of our experimental results has been that the node distribution is highly non-Poissonian [Riihijärvi2007]. In the theoretical domain we have proposed a generalized method to generate clustered point distributions that mimic reality and have analysed the implications of non-Poissonian distribution [Petrova2007a; Hoydis2008; Mähönen2007; deBaynast2007; Riihijärvi2011; Mathar2009]. Finally our spatial statistic based methods were applied to build theoretical estimation tools for radio environment maps. This work was successfully applied also to practical datasets and our Kriging-based methodology has been adopted by some of the industry researchers as a basis for their work towards developing future standards to minimize test drives – a work that is now currently under active standardization in 3GPP standardization organization [Galindo-Serrano2013; Sayrac2013]. Also interdisciplinary work between several institutes has been started to understand and develop novel distributed sensing methods and algorithms. The work has been both theoretical and practical, and recently new externally funded projects have also worked on dedicated spectrum sensing ASIC and forming a pathfinder project for future DSP development towards Radio Environment Map concepts. [Li2014; Bielefeld2010; Wellens2008a; Palaios2013c]. Similarly in TVWS domain there was a very strong interdisciplinary work between RA-A and RA-C, namely between a new junior professorship group lead by Prof. Petrova and analog circuits and RF group lead by Prof. Heinen. They were developing a new highly efficient hardware to enable use of commercial 802.11-type of WiFi systems over TV frequency bands. This work was also awarded the best paper prize in a workshop by Software Defined Radio Forum (SRIF) [Ashok2014; Subbiah2013].

WNSs. Further, we developed a joint receiver design and resource allocation for multi-hop WSNs [Wang2015] and a low-complexity set-membership affine projection channel estimation algorithm for WSNs a [Ghofrani2015]. Related to that, we investigated the energy efficiency performance of multiple DF relay systems with QoS constraints [Hu2013].

Performance of Relaying. Relaying is well known as an efficient way to improve both the capacity and the quality of service. Our research considers two main directions: the performance under the Shannon capacity regime and under the finite block length regime. Under the Shannon capacity regime, we investigate the higher-layer capacity as well as the higher-layer energy efficiency for a multi-relay system with retransmissions [Hu2015a]. Under the finite block length regime where the

error probability of the communication is no longer negligible, we address in general the analytical performance models for relaying. We observed that that the performance loss due to a finite block length (i.e., the gap between the performance under the Shannon capacity regime and under the finite block length regime) of relaying is much smaller than expected, while the performance loss of direct transmission is larger [Hu2015b; Hu2015c]. This observation shows the performance advantage of relaying under the finite block length regime.

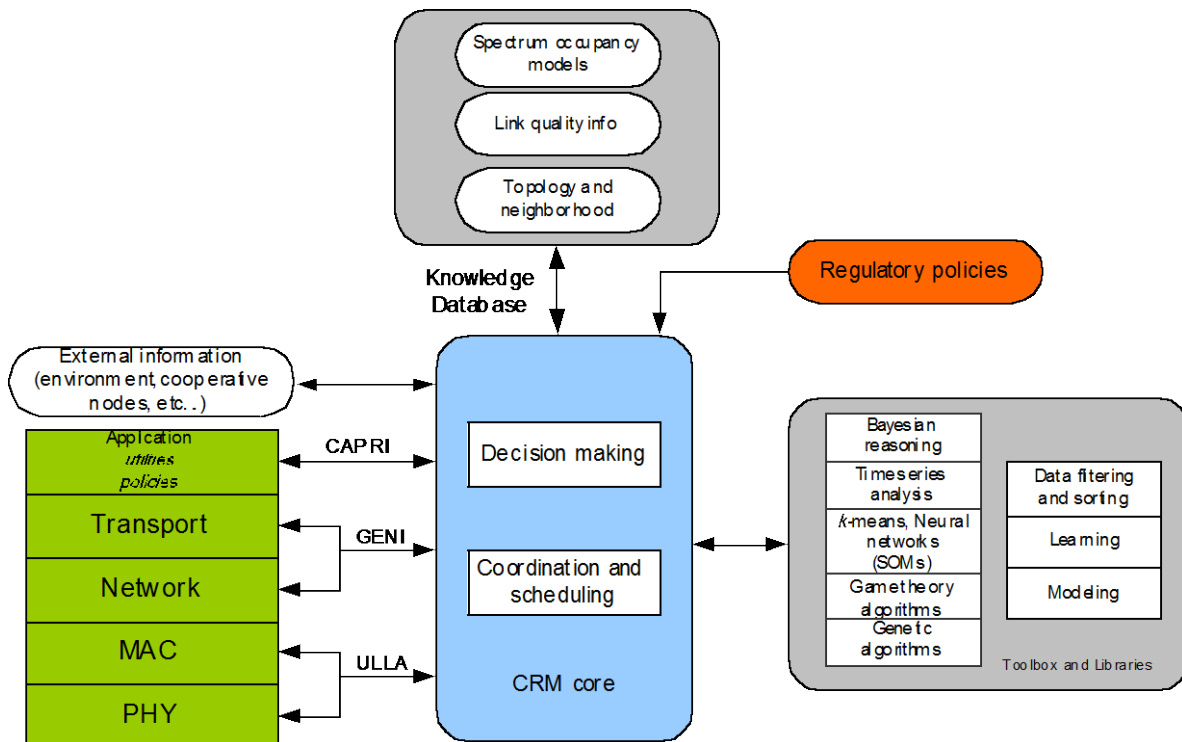

Figure 2-2: Cognitive Resource Management

Cognitive Resource Management, and particularly the UMIC concept of Cognitive Resource Manager (**CRM**), was a large architectural part of UMIC work that has also attracted later additional funding from other sources. It collected results from several projects under the same integrated architecture and prototyping system. The CRM framework has been proposed by UMIC researchers as a general architecture to enable cognitive radios that use cross-layer information and different machine learning algorithms to learn from their environment and then to adapt to changes. CRM can be seen as the first specific architecture that can be truly used to **implement** Mitola's cognitive cycle. CRM work has been published in many prestigious conferences, including initial presentation at INFOCOM, and a number of specific papers and implementation techniques have been published so far. The work done in UMIC led to the initial prototype implementation by using software defined radios in the context of smart home networking. The left figure shows the main

functional architecture of the developed CRM. The similar modular algorithm was also implemented for cross-layer optimization and implementation purposes beyond the radio network use [Kunz2009]. The insights gained while developing CRM and REM methods have been also applied to future heterogeneous and femto-cellular 5G networks [Liu2014; Voicu2014a; Voicu2014b; Liu2015; Jagadeesan2015].

The main architecture and components have been tested so far with several different hardware components, such as in Rice WARP boards, National Instrument's USRP boards, and programmable IEEE802.11 chipsets, something made possible by good resources provide through UMIC lab. One of the highlights of this work is that in the cooperative projects the new management and information interfaces ULLA (Universal Link Layer API), GENI (General Network Interface), and CAPRI (Common Application Requirement Interface) have received attention from the industry and some parts of this work are already entering into standardization (among some other CRM concepts) in IEEE P1900 and ETSI RRS groups. The programmable and adaptive cognitive MAC-layer was developed for CRM architecture as a joint work between RA-A and RA-C in the context of the Nucleus architecture. The cognitive MAC layer has been thoroughly investigated and published – in this domain also very intensive cooperation was done between RA-A and RA-C to better understand gains derived from multi-core architectures for protocol stack implementations; see [Petrova2007b; Sooriyabandara2008; deBaynast2008; Zhang2013a; Zhang2013b; Ansari2013].

Efficient Resource Management and Spectrum Allocation: As a part of UMIC research several teams have studied and developed in cooperation several resource allocation and optimization algorithms and schemes. These innovative methods have been applied further in the cognitive radio domain, and have also been implemented with functional prototypes. One of the highlights has been to study, adapt and implement so-called balls-and-bins algorithm into cognitive radios to perform joint spectrum allocation and load balancing [Fischer2008; Petrova2010b]. In the same domain we have also developed a heuristic colouring algorithm for pure channel allocation (the work which has been later picked by external partners for exploitation), and application of minority games and other evolutionary games for different resource management problems [Petrova2010a; Komali2009]. As an example, the convergence and equilibrium properties of the balls-and-bins algorithm have been analytically proven in the fluid limit, and its practical working has been demonstrated not only by simulations, but also by using USRP and WARP SDRs as a test network. In this domain also a fully programmable OFDM testbed has been developed for USRP SDRs to test novel optimization algorithms especially for power control (see details and references in section 2.2.1.3).

2.2.1.3 Major research achievements: Information theory and physical layer aspects

In this domain the overall goals and themes were **capacity, quality, efficiency, and optimisation** of wireless transport platforms. The focus was on information theoretical and physical layer aspects, both theoretical and prototyping activities were included. The main research project topics were: Reliable communication over asymmetric channels; OFDM transceiver techniques: Turbo DeCodulation and maximum likelihood reception; rate and power allocation for multiuser OFDM and resource allocation in multicell scenarios; enhancing the quality of VoIP with cross-layer-iterated soft information; UMIC channel models; adaptive error protection for scalable video coding; and energy efficient audio communication and conferencing.

Two **practical demonstrators** have been developed within this research program. These prototypes collect results virtually from all research projects and provide natural integration points for work. These demonstrators were also ensuring a strong inter-institutional cooperation.

- **UMICore Physical Layer Simulator:** This software-based simulator serves as front-end for the visualization of various physical layer concepts that have been considered within the UMIC research cluster. Using UMTS-LTE as a reference model, this simulator integrates the most important research results from all research projects. The UMICore includes various novel physical layer optimization methods as well as cross-layer concepts and realistically modelled radio channels. The simulator will also provide a very strong starting point, and competitive advantage for future research.
- **OFDM Demonstrator:** This hardware-based demonstrator is a modular reconfigurable software defined radio (using USRP SDR platform and GNU Radio software) for the real-time demonstration of OFDM link optimization and **binaural audio-visual** communication. The latter is a representative UMIC application that enables high-quality spatial audio perception for audio-visual conferencing situations. The developed demonstrator integrates results from several projects. It is a fully functional real-time wireless transport prototype with full control of all parameters inherent to OFDM(A) systems. The algorithms are extremely promising, and the developed testbeds have been among the best demonstrators in several conferences [Bielefeld2010; Zivkovic2009; Görtzen2010; Liu2009; Feiten2008; Zivkovic2011; Liu2011; Liu2012].

We have studied **OFDM Transceiver with Turbo DeCodulation, Maximum Likelihood Reception and Hybrid ARQ** by evaluating and developing various OFDM transceiver architectures and algorithms. Multiple iterative OFDM transceiver concepts such as bit interleaved coded modulation with iterative decoding (BICM-ID) and iterative Turbo DeCodulation (TDeC) have been implemented and their performance has been compared with the UMTS LTE system. Several UMIC

innovated add-ons concerning adaptivity, complexity and quality of the UMTS LTE transceiver concepts have been presented (e.g. unequal error protection for QAM modulation). All transceiver concepts, including LTE, have been analysed in regard to their influence on quality and capacity of radio access networks. Furthermore, different types of channel coding (e.g. Turbo coding vs. LDPC coding) have been carefully studied in several projects with very promising results. Additionally, code-aided synchronization and soft-input soft-output channel estimation algorithms have been investigated. Algorithms to combat the effects of non-linearities of OFDM power amplifiers as well as MIMO data detection algorithms were implemented and evaluated. Low-complexity MIMO detection with Monte Carlo techniques has been introduced and adapted for the use with imperfect channel knowledge. [Lüders2009; Schotsch2008; Breddermann2014]

Multicarrier Systems. We studied two kinds of promising multicarrier systems, wavelet based OFDM and filter bank multicarrier system and compared both to conventional OFDM. The analytical BER expressions were validated by simulation and showed that the wavelet based OFDM has a better BER performance in higher SNR region under both frequency selective and flat channels and FBMC has the same BER performance as traditional OFDM under Rayleigh channel when perfect recover conditions are satisfied. [Qinwei2013; Qinwei2015].

Our work on **Rate and Power Allocation for Multiuser OFDM and Resource Allocation in Multicell Scenarios** has aimed at optimizing the physical link properties of OFDM(A), considering both point-to-point and multi-access strategies. The main challenges were to achieve maximum bandwidth efficiency, minimum power consumption, robustness against varying channel conditions, and high-performance fair multi-user and multi-cell resource allocation. Maximizing rate and minimizing power are obviously opposed objectives. Our approach has been to minimize power subject to rate demands, or maximize rate subject to power constraints. This leads to the so-called rate or margin adaptive problem, respectively, which has been solved by fast and efficient novel algorithms using the water-filling principle. For practical applications, powerful but still efficient heuristic allocation policies have been developed and carefully evaluated against existing ones. Further investigations have opened out into exact solutions and powerful heuristics for heterogeneous resource allocation for multi-user, multi-cell scenarios. Dealing with users of different traffic demand, real time data or file transfer, say, is highly important for practical applications. New algorithmic concepts for assigning subcarriers to different users have been developed in UMIC projects and their computational complexity and performance has been numerically evaluated. Methodologically, the dual optimum is explicitly determined, which gives an upper bound to the primal optimum by the duality gap. Recently progress has been made for automatic detection of modulation schemes per subcarrier, which is an important element of power and rate allocation policies. [Feiten2008,2009a; Bielefeld2010; Görtzen2010].

As a part of this sub-research topic TI-group has implemented a modular reconfigurable software defined radio prototype using USRP radio equipment. Practical requirements from this test bed have directed further theoretical developments. Presently the demonstrator supports a **binaural audio-visual conferencing** application in real time. This is a joint development result between two different RA-A projects and a perfect example of inter-institute level cooperation. The demonstrator, and through that also theoretical work, has been demonstrated on different public occasions, e.g., at CeBIT and the World Mobile Congress in Barcelona 2011. It also won the second demonstration prize from WINTeCH 2009. A set of nodes of this testbed is also used for exploring distributed compressive spectrum sensing with smart information fusion. [Bielefeld2011; Jeub2011; Görtzen2010; Liu2009].

We developed a general framework for resource allocation which encompasses the common problem formulations. For a discrete rate function we obtained a generalized multidimensional multiple-choice knapsack problem and developed efficient rounding methods and performance bounds. In the case of concave rate functions, the general problem is a mixed-integer continuous optimization problem which we approached by Lagrangian relaxation and rounding strategies, which we showed to be asymptotically optimal. Further, we developed a low-complexity subcarrier allocation scheme based on channel gain weighting. [Görtzen2014; Görtzen2012; Görtzen2010]

A major challenge inherent to all types of wireless communication networks is uncertain data since many factors in the real problem are non-deterministic. Uncertainties originate, for example, from the movement of users, fluctuating bandwidth requirements, or changes in the quality of the transmitted signal induced by external influences such as weather. Neglecting the fluctuation of parameters in the planning phase by considering only the worst-case realization results in too conservative solutions. A methodology to handle data uncertainty is robust optimization. In this approach, the uncertain data is modelled via a deterministic scenario set. We successfully applied robust optimization to wireless network planning [Claßen2011; Claßen2013a; Claßen2013b].

Energy Efficient Audio Communication and Conferencing has been one of the important test cases and research aims within RA-A – with strong links to RA-B. The provision of auditory telepresence to multiple participants requires a centralized audio conference bridge. State-of-the-art algorithms to counter acoustic impairments like background noise or echo have been designed primarily for small terminal equipment, taking the constraints of low complexity and low bit rate transmission into account, limiting the enhancing capabilities of these algorithms. As the UMIC concept can provide high quality audio transmission, powerful audio-signal enhancement and audio-mixing functions as well as speech recognition can be moved from the mobile terminal to a network-based audio processing unit, reducing the required energy consumption of the terminal.

The relocation of background noise reduction and acoustic echo control to a network based unit has been analysed by simulating the transmission with several standardised speech codecs. The effect of these codecs on noise reduction is limited, so we have shown that relocation is possible without further changes. In the case of acoustic echo control, relocation is possible using modified algorithms. The use of simpler, waveform-based codecs enables increased audio performance at the cost of a somewhat increased bitrate. An important side problem was the drift of the sampling frequencies of the terminal and the network unit. A novel solution for adaptive resampling has been developed which enables significant performance improvement. The key issue for practical solutions is the energy budget, compromising between energy savings for audio processing and energy expenses for increased transmission bit rate. The latter heavily depends on the channel quality taking into account, e.g. the distance between base station and mobile. As a part of UMIC work we have analysed very carefully power budget issues, and developed methods to estimate and lower the power consumption. All these methods will have a direct applicability also in the industrial context.

Last but not the least we draw an attention that there has been recently an increasing amount of work on cross-disciplinary aspects between PHY-layer aspects and cognitive radio cluster of RA-A, also linked to implementation close work in RA-C. This work is bridging the gap between PHY-layer aspects and cognitive radio architecture work done in the context of CRM. The results show that cognitive radio principles can be used to enhance today's systems, and on the other hand can be used as a springboard for the future implementation of fully programmable cognitive radios. In this domain we have studied, e.g. implementation techniques for iterative transceivers, flexible waveforms for SDR, and spatially aware MIMO and beam forming techniques in the context of future cognitive radios [Gong2013, 2014; Schmitt2010; Jordan2009]

2.2.1.4 Publications

- Achtzehn2014** A. Achtzehn, D. Deling, M. Petrova, "Feasibility of a TV Whitespaces Enabled Broadband Network for High-Speed Trains", Proc. of IEEE Globecom 2014, Austin, Texas, December 2014
- Achtzehn2015** A. Achtzehn, et al., "Feasibility of Secondary Networks: Analysis Methodology and Quantitative Study of Cellular and Wi-Fi-like TVWS Deployments", IEEE Transactions on Mobile Computing, vol. 14, no. 2, pp. 373-386, February 2015
- Ansari2013** J. Ansari, X. Zhang, P. Mähönen, "A Decentralized MAC Protocol for Opportunistic Spectrum Access in Cognitive Wireless Networks", Elsevier Computer Communications, Vol. 36, No. 13, pp. 1399-1410, July 2013
- Ashok2014** A. Ashok, I. Subbiah, G. Varga, M. Schrey, A. Achtzehn, M. Petrova, S. Heinen, "WhiteLAN: Facilitate Cost-Efficient SDR Research with COTS IEEE 802.11b/g devices", Proc. of the Third Workshop of Software Radio Implementation Forum (SRIF'14), in conjunction with ACM SIGCOMM 2014, Chicago, USA, August 2014
- Bielefeld2011** D. Bielefeld, G. Fabeck, M. Zivkovic, R. Mathar, "Energy Efficient Ultra-Wideband Signaling for Cooperative Spectrum Sensing in Cognitive Radio", IEEE Vehicular Technology Conference (VTC-Spring), 2011

- Breddermann2014** T. Breddermann, B. Eschbach, P. Vary, "On the Design of Hybrid Automatic Repeat Request Schemes with unreliable feedback", IEEE Transactions on Communications, vol. 62, issue 2, pp. 758-768, Feb. 2014
- Claßen2011** G. Claßen, A.M.C.A. Koster, and A. Schmeink. Robust Planning of Green Wireless Networks. In 5th International Conference on Network Games, Control and Optimization (NetGCooP), pages 1-5, October 2011
- Claßen2013a** G. Claßen, A.M.C.A. Koster, and A. Schmeink. A Robust Optimisation Model and Cutting Planes for the Planning of Energy-Efficient Wireless Networks. Computers and Operations Research, 40(1):80-90, January 2013
- Claßen2013b** G. Claßen, A.M.C.A. Koster, and A. Schmeink. Speeding up column generation for robust wireless network planning. EURO Journal on Computational Optimization, 1(3-4):253-281, 2013
- Feiten2008** A. Feiten, R. Mathar, "Proportional QoS Adjustment for Achieving Feasible Power Allocation in CDMA Systems", IEEE Trans Comm., vol. 56, no. 2, pp. 254-259, Feb. 2008
- Fischer2008** Fischer, S., Mähönen, P., Schöngens, M., and Vöcking, B.: "Load Balancing for Dynamic Spectrum Assignment with Local Information for Secondary Users", Proc. of the International IEEE Symposium on Dynamic Spectrum Access Networks (DySPAN 2008), 2008
- Galindo-Serrano2013** A. Galindo-Serrano, B. Sayrac, S. Ben Jemaa, J. Riihijärvi, P. Mähönen, "Automated Coverage Hole Detection for Cellular Networks Using Radio Environment Maps", Proc. of WiNMe 2013, Tsukuba Science City, Japan, May 2013
- Ghofrani2015** P. Ghofrani, T. Wang and A. Schmeink, "Set-Membership Affine Projection Channel Estimation for Wireless Sensor Networks", IEEE International Conference on Communications (ICC), June 2015
- Görtzen2010** S. Görtzen, A. Schmeink, A theoretical framework for capacity-achieving multi-user waterfilling in OFDMA, in Proc.: IEEE International Symposium on Information Theory and its Applications (ISITA), Taichung, Taiwan, Oct. 2010
- Görtzen2012** S. Görtzen, A. Schmeink, Optimality of Dual Methods for Discrete Multiuser Multicarrier Resource Allocation Problems, IEEE Transactions on Wireless Communications, vol. 11, no. 10, pp. 3810-3817, Oct. 2012
- Görtzen2014** S. Görtzen, A. Schmeink, Non-Asymptotic Bounds on the Performance of Dual Methods for Resource Allocation Problems, IEEE Transactions on Wireless Communications, vol. 13, no. 6, pp. 3430-3441, June 2014
- Gong2013** Xitao Gong, A. Ispas, G. Dartmann, G. Ascheid, "Power Allocation and Performance Analysis in Spectrum Sharing Systems with Statistical CSI", IEEE Transactions on Wireless Communications, vol. 12, issue 4, pp. 1819-1831, Apr. 2013
- Gong2014** Xitao Gong, A. Ispas, G. Dartmann, G. Ascheid, "Outage-Constrained Power Allocation in Spectrum Sharing Systems with Partial CSI", IEEE Transactions on Communications, vol. 62, issue 2, pp. 452-466, Feb. 2014
- Hoydis2008** J. Hoydis, M. Petrova, P. Mähönen, "Effects of Topology on Local Throughput-Capacity of Ad Hoc Networks", IEEE 19th International Symposium on Personal, Indoor and Mobile Radio Communications (PIMRC 2008), 2008
- Hu2013** Y. Hu, J. Gross, A. Schmeink and T. Wang, "Maximizing Energy Efficiency for Multiple DF Relay System with QoS Constraint", IEEE International Symposium on Wireless Communication Systems (ISWCS), August 2013
- Hu2015a** Yulin Hu, James Gross and Anke Schmeink, "QoS-Constrained energy efficiency of cooperative ARQ in multiple DF relay systems", accepted, IEEE Transactions on Vehicular Technology, DOI: 10.1109/TVT.2015.2399398
- Hu2015b** Yulin Hu, James Gross and Anke Schmeink, "On the Capacity of Relaying with Finite Blocklength", accepted, IEEE Transactions on Vehicular Technology, DOI: 10.1109/TVT.2015.2406952
- Hu2015c** Yulin Hu, James Gross and Anke Schmeink, "On the Performance Advantage of Relaying under the Finite Blocklength Regime", IEEE Communications Letters, vol.19, no.5, pp.779-782, May 2015
- Jagadeesan2015** S. Jagadeesan, J. Riihijärvi, M. Petrova, "Impact of Three-Dimensionality of Femtocell Deployments on Aggregate Interference Estimation," Proc. of IEEE PIMRC 2015, Hong Kong, August-September 2015 (accepted)

- Jeub2011** M. Jeub, C. Nelke, H. Kruger, C. Beaugeant, P. Vary, "Robust dual-channel noise power spectral density estimation", 19th European Signal Processing Conference, 2011
- Jordan2009** M. Jordan, Xitao Gong, G. Ascheid, "Multicell Multicast Beamforming with Delayed SNR Feedback", IEEE Global Communications Conference (GLOBECOM 2009), 2009
- Komali2009** R.S. Komali, P. Mähönen, "Price of Ignorance in Dynamic Topology Control", IEEE 20th International Conference on Personal, Indoor and Mobile Radio Communications (PIMRC2009), 2009
- Kunz2009** S. G. Georg Kunz, Olaf Landsiedel and K. Wehrle, "Protocol factory: Reuse for network experimentation," in *6th USENIX Symposium on Networked Systems Design and Implementation*, 2009.
- Li2014** Huijun Li, H. Wang, G. Ascheid, "Channel Correlation Maps for Rate-Adaptive MIMO-OFDMA Systems", IEEE 79th Vehicular Technology Conference (VTCSpring), 2014
- Liu2009** C. Liu, A. Schmeink, R. Mathar, "Dual Optimal Resource Allocation for Heterogeneous Transmissions in OFDMA Systems", IEEE Global Telecommunications Conference (GLOBECOM 2009), 2009
- Liu2011** C. Liu, P. Wang, A. Schmeink, R. Mathar, Joint BS Selection and Subcarrier Assignment for Multicell Heterogeneous OFDM Unicasting, Proceedings: IEEE International Symposium on Personal, Indoor and Mobile Radio Communications (PIMRC), Toronto, Canada, September 2011
- Liu2012** C. Liu, A. Schmeink, R. Mathar, Equal rate resource allocation for multiuser OFDM, EURASIP Journal on Wireless Communications and Networking, vol. 2012, pp. 1-20, September 2012
- Liu2014** F. Liu, M. Petrova, "Traffic Load Balancing Based on User Data Rate Estimation in Heterogeneous Cellular Networks", Proc. of IEEE PIMRC 2014, Washington D.C., USA, September 2014
- Liu2015** F. Liu, J. Riihijärvi, M. Petrova, "Robust Data Rate Estimation with Stochastic SINR Modeling in Multi-Interference OFDMA Networks", Proc. of the IEEE SECON 2015, Seattle, WA, USA, June 2015 (accepted)
- Lüders2009** H. Lüders, B. Eschbach, L. Schmalen, P. Vary, "OFDM Turbo DeCodulation with Exit Optimized Bit Loading and Signal Constellations", IEEE International Conference on Acoustics, Speech and Signal Processing, ICASSP 2009, 2009
- Mähönen2007** P. Mähönen, M. Petrova and J. Riihijärvi, "Applications of Topology Information for Cognitive Radios and Networks", Proc. of IEEE DySPAN 2007, Dublin, Ireland, April 2007
- Mathar2009** R. Mathar, M. Zivkovic, "How to Position n Transmitter-Receiver Pairs in n-1 Dimensions such that Each Can Use Half of the Channel with Zero Interference from the Others", Proc. of IEEE Globecom 2009, Honolulu, Hawaii, USA, December 2009
- Palaios2013a** A. Palaios et al. "Two days of European Spectrum: Preliminary analysis of concurrent spectrum use in seven European sites in GSM and ISM bands", Proc. of IEEE ICC 2013, Budapest, Hungary, June 2013
- Palaios2013b** A. Palaios et al., "A week in London: Spectrum usage in Metropolitan London", Proc. of IEEE PIMRC 2013, London, United Kingdom, September 2013
- Palaios2013c** A. Palaios et al., "Performance Evaluation of Single-Chip Spectrum Sensing Platform for Portable Spectrum Measurements" Proc. of IEEE CORAL 2013, Madrid, Spain, June 2013
- Palaios2014a** A. Palaios et al., "From Paris to London: Comparative Analysis of Licensed Spectrum Use in Two European Metropolises" Proc. of IEEE DySPAN 2014, McLean, Virginia, April 2014
- Palaios2014b** A. Palaios et al., "When Primary Users Whisper: A Preliminary Analysis on Correlations of Population-Traffic Dynamics" Proc. of CROWNCOM 2014, Oulu, Finland, June 2014
- Petrova2007a** M. Petrova, P. Mähönen, J. Riihijärvi, "Connectivity Analysis of Clustered Ad Hoc and Mesh Networks", IEEE Globecom 2007, AHSN, Washington D.C., USA, November 2007
- Petrova2007b** M. Petrova, P. Mähönen, "Cognitive Resource Manager: A cross-layer architecture for implementing Cognitive Radio Networks", in *Cognitive Wireless Networks*, Springer, 2007

- Petrova2010a** M. Petrova, M. Michalopoulou, P. Mähönen, "Self-organizing multiple access with minimal information: Networking in El Farol bar", 2010 IEEE GLOBECOM Workshops (GC Wkshps), 2010
- Petrova2010b** M. Petrova, N. Olano, P. Mähönen, "Balls and bins distributed load balancing algorithm for channel allocation", 2010 Seventh International Conference on Wireless On-demand Network Systems and Services (WONS), 2010
- Qinwei2013** Qinwei He, Christoph Schmitz, Anke Schmeink, BEP of Fourier Transform and Discrete Wavelet Transform based OFDM, International Symposium on Wireless Communication Systems (ISWCS), Ilmenau, pp. 763-767, August 2013
- Qinwei2015** Qinwei He, Anke Schmeink, Comparison and evaluation between FBMC and OFDM systems, International ITG Workshop on Smart Antennas 2015 (WSA2015), Ilmenau, Germany, 3-5 March 2015
- Riihijärvi2007** Riihijärvi, J., Mähönen, P., and RübSamen, M.: "Characterizing Wireless Networks by Spatial Correlations", IEEE Comm Lett., vol. 11, No. 1, pp. 37-39, 2007
- Riihijärvi2011** J. Riihijärvi, J. Nasreddine, P. Mähönen, "Influence of Primary Network Structure and Dynamics on Achievable Performance of Cognitive Wireless Networks", Proc. of IEEE DySPAN 2011, Germany, May 2011
- Sayrac2013** B. Sayrac, A. Galindo-Serrano, S. Ben Jemaa, J. Riihijärvi, P. Mähönen, "Bayesian Spatial Interpolation as an Emerging Cognitive Radio Application for Coverage Analysis in Cellular Networks," Transactions on Emerging Telecommunications Technologies, Volume 24, issue 7-8, pp. 636-648, November-December 2013
- Schmitt2010** L. Schmitt and H. Meyr, "A Systematic Framework for Iterative Maximum Likelihood Receiver Design", IEEE Transactions on Communications, vol. 58, July 2010
- Schotsch2008** B. Schotsch, L.Schmalen, P. Vary, T. Clevorn, "Graph-Based Turbo DeCodulation with LDPC Codes", IEEE Vehicular Technology Conference (VTC Spring 2008), 2008
- Simic2012** L. Simic, M. Petrova, P. Mähönen, "Wi-Fi, but not on Steroids: Performance Analysis of a Wi-Fi like Network Operating in TVWS under Realistic Conditions", Proc. of IEEE ICC 2012, Ottawa, Canada, June 2012
- Sooriyabandara2008** M. Sooriyabandara, et al., "Unified Link Layer API: A Generic and Open API to Manage Wireless Media Access", Computer Comm., vol. 31 (5) 962-979, March 2008
- Subbiah2013** I. Subbiah, M. Schrey, A. Ashok, G. Varga, A. Achtzehn, M. Petrova, S. Heinen, "Design of a TV White Space Converter Prototype Towards Cognitive Radio for WLAN Routers", Proc. of CrownCom 2013, Washington D.C., USA, July 2013
- vandeBeek2011** J. van de Beek, J. Riihijärvi, A. Achtzehn, P. Mähönen, "UHF White Space in Europe – A Quantitative Study of the Potential of the 470-490 MHz Band", 2011 IEEE Symposium on New Frontiers in Dynamic Spectrum (DySPAN), 2011
- Voicu2014a** A. Voicu, L. Simic, M. Petrova, "Interference Mitigation in Two-Tier LTE Networks: Does Power Control Pay Off for Femtocells?", Proc. of IEEE PIMRC 2014, Washington D.C., USA, September 2014
- Voicu2014b** A. Voicu, L. Simic, M. Petrova, "Boosting capacity through small cell data offloading: A comparative performance study of LTE femtocells and Wi-Fi", Proc. of IEEE 6th International Workshop on Heterogeneous and Small Cell Networks in conjunction with IEEE GLOBECOM 2014, Austin, Texas, December 2014
- Wang2015** T. Wang, R. C. de Lamare, and A. Schmeink, "Alternating Optimization Algorithms for Power Adjustment and Receive Filter Design in Multihop Wireless Sensor Networks," IEEE Transactions on Vehicular Technology, vol. 64, no. 1, January 2015
- Wellens2008a** M. Wellens, J. Riihijärvi, M. Gordziel, P. Mähönen, "Evaluation of Cooperative Spectrum Sensing based on Large Scale Measurements", IEEE DySPAN 2008, USA, Oct. 2008
- Wellens2008b** M. Wellens, A. de Baynast, P. Mähönen, "Performance of Dynamic Spectrum Access based on Spectrum Occupancy Statistics", IET Comm., vol. 2 (6), 2008, pp. 772-782
- Wellens2009a** M. Wellens and P. Mähönen, "Lessons Learned from an Extensive Spectrum Occupancy Measurement Campaign and a Stochastic Duty Cycle Model", J. Mobile Networks and Applications, (doi:: 10.1007/s11036-009-0199-9), August 2009.

Wellens2009b	M. Wellens, J. Riihijärvi, and P. Mähönen, "Spatial Statistics and Models of Spectrum Use", <i>Computer Communications</i> , vol. 32, no. 18, pp. 1998-2011, December 2009.
Wellens2010	M. Wellens, J. Riihijärvi, P. Mähönen, "Evaluation of Adaptive MAC-Layer Sensing in Realistic Spectrum Occupancy Scenarios", <i>IEEE Symposium on New Frontiers in Dynamic Spectrum (DySPAN 2010)</i> , 2010
Zhang2013a	X. Zhang, J. Ansari, L.M. Amoros Martinez, N. Arbos Linio, P. Mähönen "Enabling Rapid Prototyping of Reconfigurable MAC Protocols for Wireless Sensor Networks" <i>Proc. of WCNC 2013, Shanghai, China, April 2013</i>
Zhang2013b	X. Zhang, J. Ansari, M. Arya, P. Mähönen "Exploring Parallelization for Medium Access Schemes on Many-core Software Defined Radio Architecture", <i>Proc. of the Second Workshop of Software Radio Implementation Forum, in conjunction with ACM SIGCOMM 2013, Hong Kong, August 2013</i>
Zivkovic2009	M. Zivkovic, R. Mathar, "Preamble-Based SNR Estimation in Frequency Selective Channels for Wireless OFDM Systems", <i>IEEE 69th Vehicular Technology Conference (VTC Spring 2009)</i> , 2009
Zivkovic2011	M. Zivkovic, R. Mathar, Joint Frequency Synchronization and Spectrum Occupancy Characterization in OFDM-based Cognitive Radio Systems, <i>Proceedings: IEEE Globecom 2011, Houston, USA, December 2011</i>

2.2.2 Research area B (RA-B): Application and services (ubiquitous information mobility)

2.2.2.1 Introduction

As discussed before mobility and universal access to information are becoming key requirements in the future. Information mobility does not mean only mobile applications, but denotes also the fact that we have to find technological and software engineering methods to enable mobility of information itself among devices, geographical locations and administrative domains. This must be managed without increasing complexity or reducing security and privacy. The mission of RA B has been to leverage and challenge new wireless communications platform and technologies by experimental applications and concepts. Innovative system concepts and algorithms as well as successful interdisciplinary demonstrators and industrial spin-off projects resulted in three domains: (1) mobile web servers and cross-layer adaptive protocols for ad-hoc and mesh net structures; (2) heterogeneous P2P data exchange among mobile systems, and energy-efficient data mining; (3) quality and efficiency breakthroughs for mobile 3D graphics, video and audio conferencing, and post-desktop interaction methods.

2.2.2.2 Major research achievements

One of the lessons learned since the UMTS auctions at the beginning of the new century has been that application-driven design is replacing purely technology-driven innovations in industry. The idea is to make the preferred application as easy and attractive to use as possible for users with very limited interests and technical knowledge, thus broadening the basis of potential customers.

The mission of research area B within UMIC has been to leverage and challenge new wireless communication platforms and technologies by experimental prototypical applications, and by interfacing them with novel application-level technologies. In this manner, a systematic interplay between technology push and application pull has been established. Intensive cooperation both within the research area and with the other areas, mainly the wireless transport platform research in RA-A and the cross-layer methodological research in RA-D, proved a critical success factor.

The application scenarios were organized firstly according to some of the major ***challenges facing the diffusion of mobile information and communication systems***:

- The coverage issue: rural/third-world vs. urban high-speed scenarios
- Requirements diversity concerning many small vs. few large-scale data streams
- New opportunities through the confluence of multimedia management, mobile communication, and the internet

These questions were overlaid with the ***challenges resulting from emerging new application-level technologies*** in software engineering, data engineering, and media engineering, resulting in three sub-areas

- The service perspective: Mobile web services and communities (B.1)
- The data perspective: Mobile peer-to-peer data management (B-2)
- The media perspective: Mobile media and interaction (B.3).

In all three subareas, important fundamental research results in the respective fields of computer science have been accomplished. In addition, cross-disciplinary flagship demonstrators within UMIC itself were complemented by “real-world” application projects performed in cooperation with external partners, funded typically by complementary regional sources, the EU, or industry.

The Service Perspective: Mobile Web Services and Communities (subarea B.1)

The field of mobile web services and mobile internet communities has made enormous progress since the start of UMIC. Fundamental results and successful real-world applications have been accomplished in an interdisciplinary team from Information Systems, Communication Networks, Communication Systems, and Urban Planning, focusing on the cross-layer stack of

- Web servers on small-footprint mobile devices (mobile web servers)
- Wireless ad-hoc mesh network protocols with flexible mapping to heterogeneous transport platforms (cooperation with RA-A)
- Reflective and secure multimedia service infrastructures for mobile professional communities (cooperation with RA-D).

This subarea addressed mainly a rural communication scenario with instable infrastructure conditions, as it can be found in many parts of the developing world, but also in less populated rural areas in Europe. We first discuss the most important technical results, then application-related impacts and challenges.

Technical results. While most industry and research effort has concentrated on the development of mobile clients for web services offered by stationary servers, two research groups in Electrical Engineering and Computer Science at RWTH Aachen University, in cooperation with Ericsson Eurolabs, have prototyped the internationally **first mobile web servers on smart phones** just before the official start of UMIC. In UMIC, we have further developed their theory, efficient implementation,

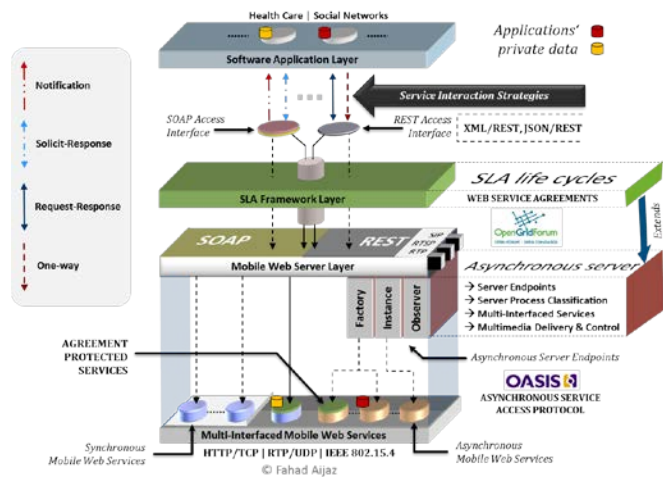

Figure 2-3: UMIC mobile web server architecture

performance and security evaluation in three doctoral theses throughout the funding period (Gehlen 2007, Srirama 2009, Aijaz 2009). Srirama is now Associate Professor and Director of the well-known Mobile Communications Lab at Tartu University, Estonia, the other two lead R&D groups on vehicular communications in a large international phone company. Mobile web servers enable multi-user access to the data on a smart-phone and are a prerequisite for mobile peer-to-peer data exchange where the smart-phones serve as both clients and servers to each other and to other nodes in a network [Srirama2009]. The research has demonstrated that SOAP-based solutions are only feasible with a relatively small load and number of parallel users, but more advanced software technologies based on a combination of REST infrastructure, reduction of code interpretation, and clever information brokering permit realistic user numbers even with transfer of multimedia. Moreover, it could be shown how asynchronous mobile web services with long duration and possibly temporary interruptions can be integrated into the system.

User and performance experiments were conducted with excerpts from both the Internet community and Healthnet scenarios mentioned below, and demonstrated high interest of users in this kind of technology. A demonstrator privacy-preserving social network in which the data are not stored on a central server as in Facebook, but remain in the possession of individual users on their own devices, was tested by more than one thousand users as part of the Ericsson Application Award competition 2010. It was awarded 4th prize in this worldwide competition in which 120

teams from 28 countries participated. The recent espionage scandals have resulted in further increased impact in this kind of approach which enables truly decentralized data ownership and control in a mobile setting.

The emergence of a variable network of mobile servers and clients creates unstable conditions in **wireless ad-hoc and mesh networks** that pose special novel challenges to **adaptive protocol behavior**. End systems should adapt to certain network conditions as well as resource restrictions of mobile devices; but also network services like routing, service discovery, and group communication need to react to changes in the networks. A broad range of scenarios was examined: (1) provisioning of basic building blocks for general composition of flexible communication services in such networks, (2) deep analysis of optimized service discovery protocols, and (3) a cross-layer framework for supporting the development of adaptive protocols.

In (1), scalable management of multicast paths and multicast groups, anycast, service composition, delegation, and service discovery were identified as basic building blocks. For the indirection functionality, a flexible and robust index structure network-wide lookup service was developed, operating without centralized components. The approach has been validated with a full implementation for the UMIC mesh testbed developed within UMIC Area D and the omnet++

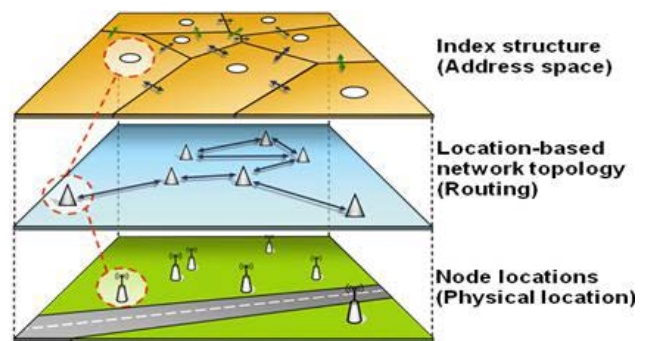

Figure 2-4: Adaptivity across protocol layers

simulator [Garcia-Morchon2007], and has been approved as an RFC in the IETF standards group [Varjonen2008]. In (2), a multi-stage service discovery protocol was developed that adapts its operation mode (called stage) to its environment and current network conditions, providing optimal performance for the application layer [Krebs2009]. The fully distributed cross-layer algorithm considers connectivity, link stability, device capabilities, and the user's current context to upgrade or downgrade its stage. In higher protocol stages, more advanced clustering techniques (k-distance dominating set based clustering) are applied to elect a virtual backbone in which certain nodes are elected as supernode, based on connectivity like wireless link stability metrics, and node profile willingness to participate. In (3) we proposed a software architecture to easily and systematically combine and coordinate multiple specific cross-layer optimizations such as (2) in a single system [Aktas2010]. In contrast to previous statically compiled solutions, it dynamically composes cross-layer optimizations at runtime and automatically activates them based on environmental conditions, network changes, and device capabilities. Moreover, we introduced an abstraction that simplified the design of cross-layer optimizations.

In the last years, **Internet communities** have gained enormous societal and economic importance, even into the political sphere. In addition to very large-scale open communities such as Facebook, thousands of medium-size organizations and interest groups in the so-called long tail of the Web face the need for dedicated support aiming at the fulfillment of very heterogeneous community needs, semantic access to shared multimedia data resources and services, self-monitoring and evaluation services, and role-based security depending on dynamically evolving trust within the community. Uncertainty reduction in a situation of data overload is a key goal to be addressed. Many members of such communities are not ICT experts; they prefer story-telling-like delivery of structured semantic information over computer science formalisms. In the mobile case, a seamless transition between indoor and outdoor navigation scenarios is also desirable.

The UMIC approach to *high-quality information services for mobile professional Internet communities* follows a metadata-based approach using real-time collaboration protocols and on the fly construction and population of ontologies which is less formal than traditional AI approaches (commonsense model) and compatible with emerging standards such as RDF, MPEG-7, and XMPP [Cao2009]. In this manner, mul-

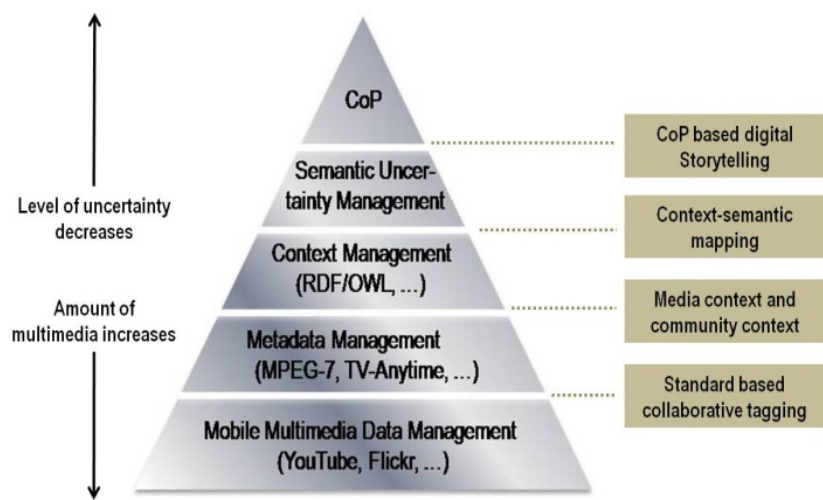

Figure 2-5: Service layers for the community knowledge pyramid

timedia objects from numerous heterogeneous sources can be annotated with semantics as well as locality, community, and other context aspects, and delivered through a mobile non-linear story-telling mechanism. These annotations, in turn, enable precise multimedia queries to the community media base. Social Network analysis could thus be expanded by aspects of actor-network theory such that much richer patterns of community analysis and evolution could be achieved [Pham2011]; this was demonstrated, among other things, by the first study of the evolution of the Computer Science community over the past 40 years, including a formal “proof” of the often made claim that top conferences in computer science are at least equally influential on the field as its top journals. The community framework developed in UMIC also serves as a service integration engine for the special data fusion and analysis services developed in section B.2, and the highly advanced media capture and delivery services developed in section B.3. Results of

this work were published regularly at the Mobile Data Management (MDM) conference and in international journals. Moreover, through a series of workshops, influence on standardization groups has been accomplished: The multimedia metadata workshop series led to a W3C media annotations working group proposing different recommendations regarding interoperable annotations to the Web community. Out of a UMIC workshop a new workshop series “Pervasive Communities and Service Clouds” has been started at the IEEE Pervasive Computing (PerCom) conference. Many of the technical results have been published in Github as Open Source Software where they are widely used by other researchers and small companies. In addition, demos of the work on mobile requirements analysis and mobile cloud research have received three best demo awards in the IEEE International Conference on Requirements Engineering (2014) and International Conference on Web Engineering (2014 and 2015).

Interdisciplinary demonstrators. As an initial demonstrator scenario, we have pursued a cultural heritage management and reconstruction community application domain in rural settings of the third world. Due to the highly heterogeneous, technologically and politically instable setting, and the different expertise and competence levels of community members, this typifies many of the challenges faced especially in the third world. As mobile multimedia data collection and storytelling in varying social settings play a key role, the metaphor of a *Virtual Campfire* has been chosen for this scenario [Klamma2009]. The Virtual Campfire approach has captured strong attention (and additional third-party funding) in international organizations such as UNESCO/ICOMOS. The Virtual Campfire demonstrator was shown on the MDM 2008 conference and won the best demo award at the I-Know conference 2007. The mobile version was the first app provided by RWTH Aachen University in the Apple AppStore. It has been tried out in practice in the city reconstruction planning for the Bamiyan Valley in Afghanistan [Toubekis2011], as well as in smaller experiments with a history reconstruction of the last surviving World War I battleship located in Greece, and a Gandhara exhibition in the Bundeskunsthalle in Bonn. Moreover, it formed the IT basis for the mobile ICT preparation of the Afghan city of Ghazni as the Islamic Culture Capital 2013, whose documentation book will be officially handed over between the Foreign Ministers of Germany and Afghanistan in summer 2015, and a planned complete art-history survey of medieval Omani cities. In connection with network theories of learning (e.g. reviewed in [Chatti2012]) the approach has also been tested in numerous eLearning projects exceeding more than 15 Million Euro of funding, among others the LogiAssist mobile continuous training system developed with the NRW transport association in which truckers can fulfil legal continuous education needs while on the road. Further applications and extensions include the largest EU projects in the Technology-Enhanced Learning area (ROLE and Learning LAYERS), and the BMWi lighthouse project eConnect for ICT support for multimodal electro-mobility.

A second large-scale demonstrator project for application- and transport-level UMIC results has been started in the Aachen region itself. The **Mobile ACcess** project co-funded by regional government, local businesses and service providers, and the state of NRW. It explores alternatives to provider-centric networks by allowing users to contribute to the network infrastructure as micro-operators. The project focuses on cooperative network concepts and services in such networks. User cooperation allows for providing very low-cost, high-speed mobile Internet services, ranging from tourism to shopping to education. The project demonstrates its results in a joint test-bed be-

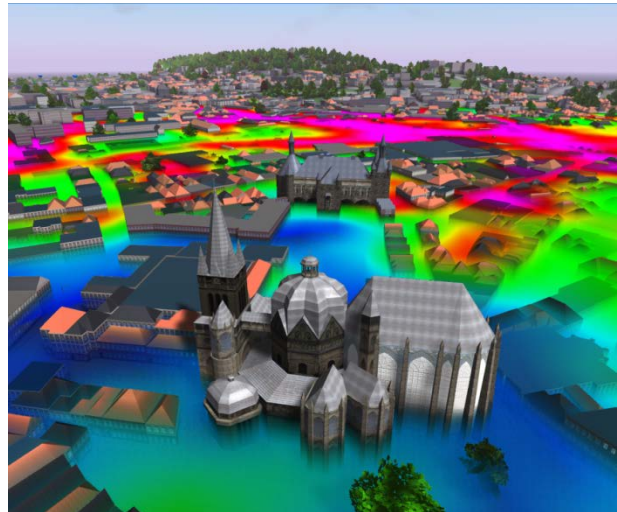

Figure 2-6: WiFi coverage downtown Aachen

tween RWTH Aachen University, city of Aachen, regioIT, LANCOM Systems, the Fraunhofer Institute FIT, and other partners from industry. The project also explores options for providing Wi-Fi in the neighboring rural Eifel communities which have so far been poorly served by high-speed communication providers (both fixed and wireless). The core challenges in the network area are the provision of a homogeneous Wi-Fi system based on heterogeneous and isolated Wi-Fi access points of individual users. For the establishment of trust and security, the project uses a certificate-based distributed firewall and mobile tunnels to enable users to roam between the different Wi-Fi islands. The main focus of the service domain is location-based services and intuitive ways for users to access and interact with these. The basis for such intuitive interface is a 3D reconstruction of a city (cf. subarea B.3).

The Data Perspective: Mobile Peer-to-Peer Data Management (subarea B.2)

As foreseen in the UMIC proposal, data traffic in mobile communication has exceeded voice traffic during the funding period. As a simple example, YouTube videos are currently accounting for almost 10% of the mobile communications traffic. At the same time, mobile communication itself creates an enormous amount of tracking data as well as making application data available over the air to a much larger number of users than ever (more people in the world now get their data via smartphone than via PC). In contrast to voice communication, machine to machine data communication in an increasing variety of formats and devices is becoming a significant part of this traffic – i.e. the Internet of Things and Services is beginning to include mobile and wearable components with typically low energy supply. Data heterogeneity, information overload, energy consumption and security have become ever increasing problems.

This subarea of UMIC was particularly suitable to address not only the transfer of classical stationary data management and data mining solutions to the mobile case, but also to interlink with the method-oriented research on energy efficiency and security/privacy in Area D. Five UMIC professorships (Information Systems, Data Management & Mining, Security & Privacy, Medical IT, and Textile Engineering) supported by a special postdoc group on Interoperability have closely collaborated on this topic.

Technical Results. Mobile P2P data exchange in changing cooperation settings requires rapid and mostly automatic mapping of the heterogeneous schemas found in data sources and data user applications. The research theme of *heterogeneous model management and data integration* becomes significantly more challenging in mobile P2P settings. In many cases, data may be transferred a pre-integrated over several steps, requiring a composition of such mappings in several steps. Unfortunately, the existing model management literature has addressed heterogeneity of data models (e.g. SQL, XML semi-structured web data, object-oriented program data, various conceptual data models, data stream formats) only for specific pairs of models, not for a general multi-model setting. Moreover, compositionality of mappings had been achieved only under narrow conditions, and not at all for the heterogeneous case.

Generalizing and refocusing earlier work, UMIC has developed the first formally consistent and tractable solution to this problem. A prototypical implementation has been demonstrated successfully at several leading international conferences and is now already being used by some research groups in Germany, Israel, and the US. The starting point for dealing with heterogeneity is a role-based generic meta model which is specified as an extended Datalog formalism with predefined predicates for abstraction mechanisms; these mechanisms and the algorithms working on them for schema matching (=informal automatic preprocessing), formal schema matching, query processing and update propagation have been designed in such a way that mappings are compositional even across multiple formalisms, and thus query processing and update propagation work efficiently (using extended query optimization techniques) across chains of heterogeneous peers [Kensche2009, Li2010, Jarke2014].

In *mobile data stream mining*, the key challenge is to capture and analyze data that are only seen once as they stream by, under uneven receiver quality, and with very limited energy and computational resources on the mobile devices. This research field was for the first time systematically explored within UMIC with three different strategies: Firstly, a group of novel anytime classification data stream algorithms has been developed and evaluated theoretically as well as empirically, with lossless data aggregation under varying conditions; short-term prediction methods were developed both to accommodate direct application needs, but also to be able to bridge

short-term loss of connectivity. Practical evaluations proved the high benefit of the anytime classifiers for data streams with varying arrival rates for which they are designed, but show also significant quality improvements for classifying data streams with constant arrival rates [Kranen2009].

Secondly, by considering multiple streams that represent a certain context, a novel context-aware prediction method together with a storage-aware data structure was introduced. The whole model was tested in an energy efficient client-server scenario for analyzing the current context extracted from multiple streams. The method uses more information about current context to predict future readings of some stream of interest more accurately. Thirdly, the first algorithm for anytime modeling of stream data by means of an on-line clustering algorithm was proposed [Kranen2011] and integrated into the Massive Online Analysis (MOA) framework in collaboration with the University of Waikato, New Zealand [Kremer2011]. In close cooperation with the energy efficiency section of Area D, innovative “index-on-the-air” data structures were invented and validated which significantly reduce the amount of data downloaded for multimedia retrieval from heavy data streams. Significant energy savings are achieved by accordingly scheduling the receiver’s standby mode in the mobile devices. A complementary idea pursued here was also to focus data movement on time windows where connectivity is very good, as opposed to many present systems that waste most energy in situations where connectivity is bad, such that there low quality of results despite high energy consumption.

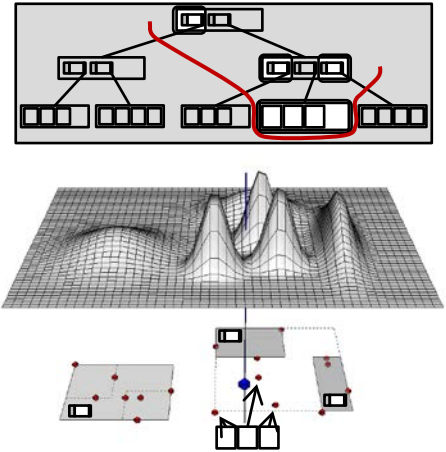

Figure 2-7: Index-on-the-air support for mobile data mining

Results of this subarea were published in top conferences of the database field (VLDB, SIGMOD, CIKM, ER, ICDE, MDM), and in a number of articles in leading journals.

Interdisciplinary demonstrators. Within UMIC itself, a **mobile HealthNet** has been chosen as a common demonstrator application, where the above-mentioned technical results were implemented on a mobile network of smartphones, and linked to further application-specific research results achieved in cooperation with institutes of textile engineering (for wearable computing monitoring of ECG, temperature and acceleration) and medical IT (mobile sen-

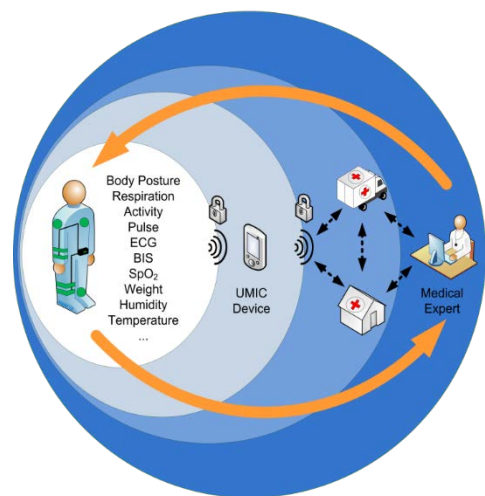

Figure 2-8: UMIC Healthnet

sensor data integration, linked with a wireless body sensor network), and with the security and privacy section of Area D (privacy-preserving data integration and analysis). Early versions of the system were demonstrated successfully in leading conferences of the medical informatics and database sectors [Kranen2008], a major real-world demonstration with several runners on the occasion of the 2011 public Lousberg run in Aachen. This included contextualization aspects such as personalized user interfaces on the mobile devices, and short-term prediction of running performance, in addition to the health parameter monitoring.

Additionally, our mobile peer-to-peer data integration and fusion results have also been transferred into the CoCarX BMBF project on **mobile car-to-infrastructure data management** [Geisler2012]. Moreover, several European Integrated projects integrating the *Internet of People, Things, and Services* led by UMIC member institutes (e.g. the BRIDGE and ebbits projects at Fraunhofer FIT) add application domains of emergency management, food chain control, and factory integration to the set of test beds.

The Media Perspective: Mobile Media and Interaction (subarea B.3)

In addition to conceptual service modeling and data handling, the growing usage of rich multimedia such as photos, video, audio, and high-quality graphics poses additional bandwidth and quality-of-service challenges that require novel media-specific algorithms as well as innovative interaction concepts. UMIC research has shown that these are not limited to the application layer alone but require interaction with other research areas, especially the Wireless Transport Platform (RA-A).

As part of the UMIC structural measures, the junior research group “**Mobile Multimedia Processing**” (MMP) was established in August 2008 by appointing Bastian Leibe. The research group’s main research focus is on computer vision and machine learning techniques for mobile applications and moving platforms, in particular on visual object recognition, tracking, image-based localization, and mobile visual search. Between 2008 and the end of the UMIC funding period, group members have won a best paper award at ICRA’09, an Intel Early Career Faculty Honor Program Award, a Google Faculty Researcher Award, an ERC Starting Grant, and the U.V. Helava Award for the best paper in the 4-year period 2008-2011 in the ISPRS International Journal of Photogrammetry and Remote Sensing. It is therefore one of the particular successes of the UMIC structural measures that Bastian Leibe’s position could be upgraded to a permanent W2 position covered by RWTH basic funding in November 2011. The successful research in this area is going to be continued in a number of further follow-up projects, in particular the ERC Starting Grant project CV-SUPER (Bastian Leibe) and the ERC Advanced Grant project ACROSS (Leif Kobbelt).

Technical results of the subarea include closely related contributions from computer graphics, image processing, data mining, human-computer interaction, audio and video conferencing, contributed by six groups from computer science and electrical engineering.

An integration of techniques from *computer vision, computer graphics, and data mining* enables the **LocalizeMe scenario**. LocalizeMe allows a pedestrian to achieve image-based self-localization in a quality well beyond current commercial offerings. This is on the one hand based on fast and reliable feature-based image matching algorithms which scale to very large image databases [Sattler2011, Weyand2015], and on the other hand on mobile object detection, recognition, and tracking for different object classes

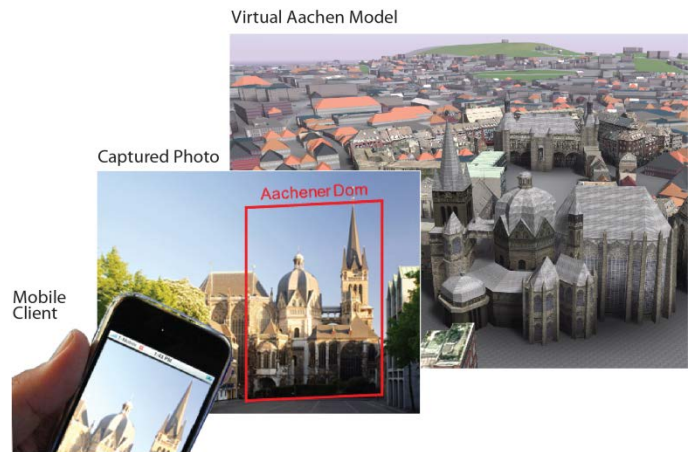

Figure 2-9: Example of LocalizeMe scenario

[Ess2009]. Real-time algorithms for these visual capabilities have been developed targeted especially at the use on mobile devices. Equally important is the high-quality stream rendering of massive 3D models (textured polygon meshes), which adapts automatically to the available bitrates of the mobile connection. Specific new algorithms in this context were developed for ad-hoc mobile multi-displays (connecting multiple mobile devices to a larger display), and for 2.5D video streaming for low latency interaction on mobile devices [Li2011]. Concerning the optimization of polygon meshes, a seminal paper on global optimization of polygonal meshes should be mentioned [Bommes2009] which has been further extended in [Bommes2013]. The developed prototypes are based on the same mobile application framework also employed in subarea B.1, thus technically enabling an interaction of this media-related research to the mobile services and communities setting.

The **reconstruction of 3D environment models** as the prerequisite to such image-based localization scenarios has until recently been a very expensive, mostly manual undertaking. UMIC research has brought a breakthrough here, with a cost reduction by about a factor of 100. Our algorithms for the interactive 3D reconstruction of objects, rooms, and even whole cities (named Mesh-Paint, LaserBrush, CityModeler) [Habbecke2009] and [Unzelmann2013] pursue a crowdsourcing approach to 3D city modeling from many 2D photographs registered fully automatically with aerial photographs and coarse-grained maps in order to create highly detailed 3D models of urban scenes. An interesting contribution to the research issues addressed in Area A has been based on this model, namely the usage of the 3D models to assist the interactive construction

and rendering of simulation models for radio wave propagation (field strength, delay spread, ...) with variably placed senders and receivers in a city; very high performance is achieved by using GPUs also for the simulation [Schmitz2009].

A significant cross-disciplinary breakthrough has been achieved in the field of **mobile video- and audio-conferencing**, an area still suffering from major quality problems in practice but with a great potential of e.g. reducing business travel and thus the human carbon-dioxide footprint. Prof. Ohm's work on H.264 video compression received a Grammy Award for the second time, in addition a joint effort between RA-A and RA-B demonstrated a major leap in the audio quality of mobile voice-over-IP. The evolution in cellular networks towards Internet communication, combined with the high error rates of wireless transmission, creates problems for traffic that can tolerate a certain amount of transmission error. In packet-switched networks, packets with even single bit errors are discarded and retransmitted. Our novel heuristic error tolerance and repair scheme for both payload and control information (headers) in packet-switched networks substantially reduces the need for retransmissions and therefore increases efficiency while reducing transmission delay. Such a scheme also facilitates the use of highly efficient iterative PHY-APP ISCD codecs (one focus of the work in re-search area A) in packet-switched networks. Furthermore, the combination of header-based control information with ISCDs leads to a novel iterative cross-layer approach that exchanges information between the physical, network, transport, and application layers to decrease the number of decoding errors, further improving the voice quality over a noisy channel (cf. also subarea B.1). The quality jump was demonstrated both in extensive simulations [Breddermann10], and in a prototype implementation that shows that efficient ISCD codecs are now finally usable in packet-switched networks. The demonstration of these accomplishments at the Mobile World Fair in Barcelona 2011 found high interest in science and industry, patents are pending.

In **mobile interaction**, the explosive growth and diversification of mobile devices had created major new challenges and research opportunities for UMIC. Compared to the desktop, mobile user interfaces face much tougher technical limitations in display and input device size, power consumption, memory, and performance. More crucial, however, were the new usage patterns—mobile devices being used in public environments, while walking, and with attention split between device and environment. These challenges required new and appropriate interaction techniques. On the other hand, new mobile form factors, sensor, input and output technologies, such as cameras, gyroscopes, accelerometers, GPS, capacitive multi-touch, wearable and bendable displays, or haptic feedback, created opportunities for new interaction paradigms. Consequently, and complementing the research on metadata and basic graphics algorithms, UMIC research in

Mobile Human-Computer Interaction (HCI) has developed and studied new interaction techniques for audio/video, multi-touch/haptics, and wearable/physical computing: *DRAGON* redefines how we can navigate through mobile videos [Karrer2008]; *CORONA* proposes a new type of continuous-3D audio virtual reality for mobile users; *Swabbing* makes mobile touch screens accessible to users with hand tremor [Wacharamanotham2011]; *MudPad* adds haptic multitouch feedback to touch screens [Jan-

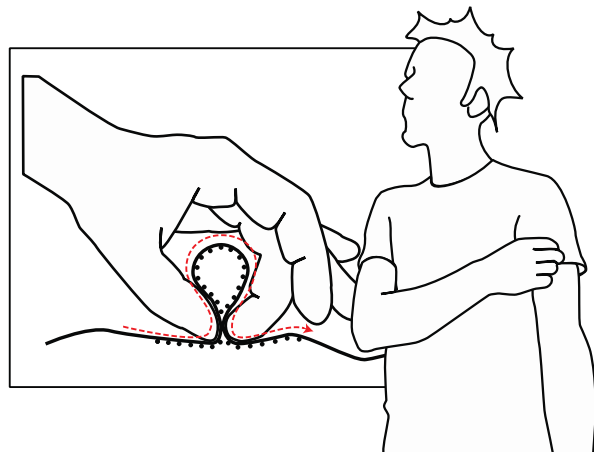

Figure 2-10: PINSTRIPES

sen2010, award]; *SensAct* defines and implements a language for tactile full-body motion instructions [Spelmezan2009]; *Pinstripe* (see Figure 2-10) enables eyes-free input on interactive clothing, complementing the wearable data management research in subarea B.2 [Karrer2011], and *TWEND* explores interactions with a bendable eBook reader. Several prototypes from these research projects were featured with great success at public exhibitions and in the media. This research into new form factors for mobile interaction would not have been possible without establishing Germany's first *Fab Lab* at RWTH, a unique workshop providing researchers (and even the general public) with access to digitally controlled 3D printers, laser-cutters, PCB mills, etc., to rapidly sketch, design, build, and evaluate their interface prototypes in hard- as in software.

Interdisciplinary demonstrators focus mostly on city tourism scenarios. The **Virtual Aachen** demonstrator is closely linked to the already mentioned Mobile ACcess application project. Several new mobile interaction techniques are developed and evaluated further in the **Aixplorer** (see Figure), a 1.5 Mio. Euro state-funded research project to explore new mobile tourist guide systems and concepts, with a sample deployment in historic Aachen in the city's key strategic tourism project. The Human-Computer Interaction group also developed Germany's Silhouettes gesture-based interactive experience at the 2010 World Expo in Shanghai, with over half a million visitors (including then-president Horst Köhler). Several of the fundamental graphics algorithms are already in commercial use by a number of companies.

2.2.2.3 Publications

Aijaz2009

Aijaz, F., Adeli, S., M., Walke, B., "A service-oriented approach for in-network computations in wireless networks", Proc. of WOCN 2009, April 2009

Aktas2010

Aktaş, I., Otten, J., Schmidt, F., Wehrle, K., "Towards a Flexible and Versatile Cross-Layer-Coordination Architecture", Proc. of IEEE INFOCOM 2010, San Diego, CA, USA, March 2010

- Bommes2009** Bommes, D., Zimmer, H., and Kobbelt, L.: „Mixed Integer Quadrangulation“, ACM Trans. Graphics 28 (3), 2009 (SIGGRAPH 2009)
- Breddermann2010** Breddermann, T., Lüders, H., Vary, P., Aktaş, I., Schmidt, F., "Iterative Source-Channel Decoding with Cross-Layer Support for Wireless VoIP", Proc. of the International ITG Conference on Source and Channel Coding, Siegen, Germany, January 2010
- Campen20012** Campen M., Bommes D., Kobbelt L., "Dual loops meshing: quality quad layouts on manifolds", ACM Trans. Graphics 31 (3), 2012 (SIGGRAPH 2012)
- Chatti2012** Chatti, M.A.; Schroeder, U.; Jarke, M., "LaaN -- Convergence of Knowledge Management and Technology-Enhanced Learning". IEEE Transactions on Learning Technologies, vol. 5, issue 2, pp. 177-189, 2012
- Cao2009** Yiwei Cao; Jarke, M.; Klamma, R.; Mendoza, O.; Srirama, S.N., "Mobile Access to MPEG-7 Based Multimedia Services", Mobile Data Management, pp. 102-111, 2009
- Ess2009** Ess, A., Schindler, K., Leibe, B., Van Gool, L., "Robust Multi-Person Tracking from a Mobile Platform", IEEE Transactions on Pattern Analysis and Machine Intelligence, vol. 31, no. 10, pp. 1831–1846, 2009
- Garcia-Morchon2007** Garcia Morchon, O., Baldus, H., Heer, T., Wehrle, K., "Cooperative Security in Distributed Sensor Networks", Proceedings of the 3rd IEEE International Conference on Collaborative Computing: Networking, Applications and Worksharing, CollaborateCom 2007
- Gehlen2007** Gehlen G., Aijaz F., Zhu, Y., Walke, B., "Mobile P2P Web Services using SIP", Mobile Information Systems , vol. 3, no. 3,4, pp. 165-185, December 2007
- Geisler2010** Geisler, S., Quix, C., Schiffer, S., "Data Stream-based Evaluation Framework for Traffic Information Systems", ACM SIGSPATIAL International Workshop on GeoStreaming (IWGS) 2010, November 2, 2010, San Jose, CA, USA
- Habbecke2007** Habbecke M., Kobbelt L., "A surface-growing approach to multi-view stereo reconstruction", IEEE Conference on Computer Vision and Pattern Recognition (CVPR) 2007
- Habbecke2009** Habbecke, M., and Kobbelt, L., "An Intuitive Interface for Interactive High Quality Image-Based Modeling", Proc. of 17th Pacific Conference on Computer Graphics and Applications, Pacific Graphics 2009 (PG 2009), vol. 28, no. 7, Jeju, Korea, Computer Graphics Forum, October 2009
- Jansen2010, award** Jansen, Y., Karrer, T., Borchers, J., "MudPad: Tactile Feedback and Haptic Texture Overlay for Touch Surfaces", Proceedings of the ACM International Conference on Interactive Tabletops and Surfaces (ITS10), pages 11–14, New York, NY, USA, November 2010. ACM. Best ITS 2010 Note Award
- Jarke2014** Jarke, M.; Jeusfeld, M.A.; Quix, C., "Data-centric intelligent information integration - from concepts to automation", Journal of Intelligent Information Systems, vol. 43, issue 3, pp. 437-462, Dec. 2014
- Karrer2008, award** Karrer, T., Weiss, M., Borchers, J., Lee, E., "DRAGON: A Direct Manipulation Interface for Frame-Accurate In-Scene Video Navigation", CHI 2008, Human Factors in Computing Systems, Florence, Italy, April 2008
- Karrer2011** Karrer, T., Wittenhagen, M., Lichtschlag, L., Heller, F., and Borchers, R.: "Pinstripe: Eyes-free Continuous Input on Interactive Clothing", Proc. of the Conference on Human Factors in Computing Systems (CHI 2011), Vancouver (Canada), May 2011
- Kensche2009** Kensche, D.; Quix, C.; Xiang Li; Yong Li; Jarke, M., "Generic schema mappings for composition and query answering", Data & Knowledge Engineering vol. 68, issue 7, pp. 599-621, July 2009
- Klamma2009** Klamma, R.; Toubekis, G.; Yiwei Cao; Renzel, D.; Jarke, M.; Jansen, M., "Virtual Campfire - Cultural Heritage Management and Presentation on Mobile Devices based on Interoperable Cross-Plattform MPEG-7 Multimedia Web Services", 22nd CIPA Symposium - Digital Documentation, Interpretation & Presentation of Cultural Heritage, Kyoto, Japan, October 2009
- Kranen2008** Kranen, P., Kensche, D., Kim, S., Zimmermann, N., Müller, E., Quix, C., Li, X., Gries, T., Seidl, T., Jarke, M., Leonhardt, S., "Mobile Mining and Information Management in HealthNet Scenarios", Proc. of MDM 2008, Beijing, China, pp. 215–216, IEEE Computer Society, Conference Publishing Services, April 2008

- Kranen2009** Kranen P., Assent I., Baldauf C., Seidl T., "Self-Adaptive Anytime Stream Clustering", Proc. IEEE International Conference on Data Mining (ICDM 2009), Miami, USA P.249-258 (2009)
- Kranen2011** Kranen P., Assent I., Baldauf C., Seidl T., "The ClusTree: indexing micro-clusters for anytime stream mining", Knowledge and Information Systems, vol. 29, issue 2, pp. 249-272, Nov. 2011
- Krebs2009** Krebs, M., Krempels, K.-H., "Optimistic On-demand Cache Replication for Service Discovery in Wireless Mesh Networks", Proc. of IEEE CCNC 2009, Las Vegas, Nevada, USA, Jan 2009.
- Li2010** Li, Xiang; Quix, C.; Kensche, D.; Geisler, S., "Automatic Schema Merging Using Mapping Constraints Among Incomplete Sources", 19th ACM international conference on Information and knowledge management (CIKM'10), Toronto, 2010
- Li2011** Li, M., Schmitz, A., Kobbelt, L., "Pseudo-Immersive Real-Time Display of 3D Scenes on Mobile Devices, Proc. of 3DIMPVT 2011, Hangzhou, China, May 2011
- Mitzel2010** Mitzel D., Horbert E., Ess A., Leibe B., "Multi-Person Tracking with Sparse Detection and Continuous Segmentation", European Conf. on Computer Vision (ECCV 10)
- Pham2011** Pham, M.C.; Yiwei Cao; Klamma, R.; Jarke, M., "A Clustering Approach for Collaborative Filtering Recommendation Using Social Network Analysis", Journal of Universal Computer Science (UCS), vol. 17, issue 4, pp. 583-604, 2011
- Sattler2009** Sattler T., Leibe B., Kobbelt L., "SCRAMSAC: Improving RANSAC's efficiency with a spatial consistency filter", IEEE International Conf. on Computer Vision (ICCV), 2009
- Sattler2011** Sattler, T., Leibe, B., Kobbelt, L., "Fast image-based localization using direct 2D-to-3D matching", Proc. of ICCV 2011, Washington, DC, USA, November 2011
- Schmitz2009** Schmitz, A., Rick, T., Karolski, T., Kobbelt, L., and Kuhlen, T.: "Simulation of Radio Wave Propagation by Beam Tracing", Eurographics Symposium on Parallel Graphics and Visualization, 2009 (Best Paper Award)
- Spelmezan2009** Spelmezan, D., Hilgers, A., Borchers, J., "A Language of Tactile Motion Instructions", Proceedings of the MobileHCI 2009 Conference on Human-Computer Interaction with Mobile Devices and Services, pages 218–221, New York, NY, USA, September 2009. ACM Press
- Srirama2009** Srirama, S., Jarke, M., "Mobile hosts in enterprise service integration", Intl. J. Web Engineering and Technology 5, 2 (2009): pp. 187-213
- Toubekis2011** Toubekis, G., Mayer, I., Döring-Williams, M., Maeda, K., Yamauchi, K., Taniguchi, Y., Morimoto, S., Petzet, M., Jarke, M., Jansen, M., "Preservation and Management of the UNESCO World Heritage Site of Bamiyan: Laser Scan Documentation and Virtual reconstruction of the Destroyed Buddha Figures and the Archaeological Remains", IPA Heritage Documentation Best Practices and Applications, Series I, 2007 2009 2011, Eds. Stylianidis E., Patias, P. and Santana, M., International Archives of Photogrammetry, Remote Sensing and Spatial Information Sciences, Vol. XXXVIII, Part 5/C19
- Untzelmann2013** Untzelmann O., Sattler T., Middelberg S., Kobbelt L., "A Scalable Collaborative Online System for City Reconstruction", ICCV Workshop on Big Data in 3D Computer Vision, 2013, BEST PAPER AWARD
- Varjonen2008** Samu Varjonen, S., Heer, T., "HIP Certificates (Version 1)", Internet-Draft, Internet Engineering Task Force, 2008
- Wacharamanotham2011** Wacharamanotham, C., Hurtmanns, J., Mertens, A., Kronenbuerger, M., Schlick, C., Borchers, J., "Evaluating swabbing: a touchscreen input method for elderly users with tremor", Proc. of CHI 2011, New York, USA, May 2011
- Weyand2011** Weyand, T., Leibe, B., "Discovering favorite views of popular places with iconoid shift", Proc. of ICCV 2011, Washington, DC, USA, November 2011
- Weyand2015** Weyand T., Leibe B., "Visual Landmark Recognition from Internet Photo Collections: A Large-Scale Evaluation", Computer Vision and Image Understanding, Vol 135, pp. 1-15, 2015

2.2.3 Research area C (RA-C): RF subsystems & SoC design (flexible terminal technology)

2.2.3.1 Introduction

RA-C was primarily concerned with efficient, flexible hardware and low-level software support for PHY and MAC layers, and simultaneously provides key technologies for higher ISO/OSI layers in future terminals and network infrastructures. The major objectives were (1) to enable ubiquitous mobile network access via efficient usage of the radio spectrum up to 3 GHz and (2) to boost performance, energy efficiency, and design productivity of system-on-chip (SoC) platforms in mobile terminals. Both flagship projects, Nucleus and Flexible RF transceivers, received significant international recognition, as indicated by numerous publications, awards, keynote talks, event organizations, exhibition booths etc. as well as by concrete demonstrator designs and industrial technology transfers.

2.2.3.2 Major research achievements: Flexible RF subsystems

Overview: Multiband and multistandard operation has become the major objective in the research on RF subsystems. SAW-less RF frontends for quadband GSM as well as the removal of interstage SAW filters for 3G and 4G frequency division duplex systems are important to reduce the complexity in today's smart phones. The RF system and RF IC team (Heinen, Negra) has implemented and evaluated different concepts tackling the described RX issues, e.g. the active feedback interference mitigation for GSM and the use of notch filters to suppress the LO leakage in FDD systems. A second, prize winning, RF activity has been the research on digital friendly transmitter architectures suited to nanoscale CMOS implementation. The successful implementation and realization of an IQ based RF DAC in 65nm CMOS provides the basis for future research in the field. The EEEf-COM Innovation Prize grants the access to a 28nm CMOS technology allowing the evaluation of different RF DAC topologies in this advanced technology node.

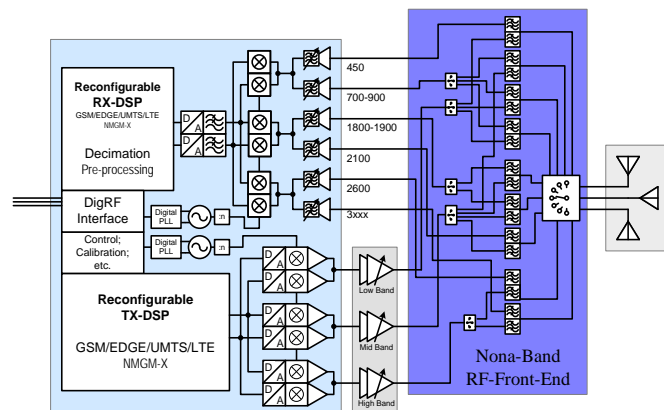

Figure 2-11: Nona-band RF-front end

Receiver: The change from SiGe BiCMOS based RF transceivers to pure CMOS based RF macros for SoCs have been much faster than anticipated in the original UMIC proposal. Digital friendly nanoscale CMOS compatible receiver architectures have converged into the use of high dynamic range continuous $\Sigma\Delta$ -based A/D converters providing an excellent dynamic range, which

allows the simplification of the RF frontend as shown and discussed in [Werth2011, Bertan]. Thus the focus of the UMIC research has been on techniques enabling the removal of external SAW or FBAR filters in order to reduce the complexity of a multiband frontend. Active interference cancellations techniques have been fundamentally investigated. A GSM prototype frontend based on this concept has been realized successfully [Werth11].

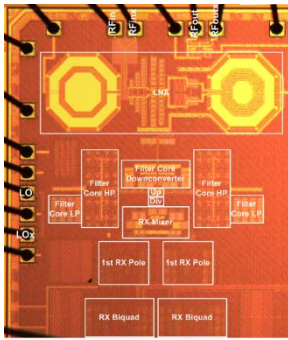

Figure 2-12:

Tx leakage rejection filter

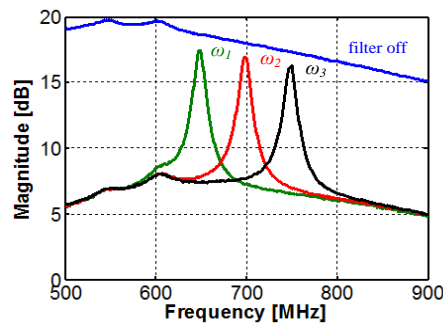
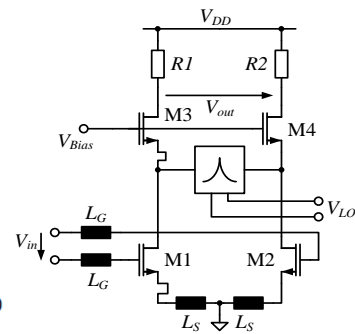

Figure 2-13: Frequency agile filter



A notch filter based TX leakage rejection has been evaluated and implemented and evaluated as well, see Figure 2-12 [Bormann2011]. A comprehensive knowledge and some experience regarding techniques increasing the dynamic range have been gathered. As RF frontends for whitespace devices in the UHF band are of particular interest a first prototype exploring the capabilities of frequency agile filters based on time-varying filter cores has been realized. The results as shown in Figure 2-13 are promising. Based on these results a TDD and half-duplex FDD cognitive radio frontend for the UHF band seems to be feasible for the second phase of the UMIC cluster. A cooperation with a start-up company mimoON providing evaluation and test hardware for communication standards has been continuously build up.

Transmitter: Digital RF techniques have turned out to be highly attractive for the implementation of a multistandard multiband transmitter in an advanced nanoscale CMOS technology node. Thus a new broadband digital centric transmit architecture has been developed and implemented. The so called IQ-RF DAC combines the DAC function as well as the up-conversion mixing into single analogue unity cell using switched-mode transistors as shown in the above block diagram. Due to its novelty and innovation potential the concept has attained the EEEfCOM Innovation award 2009. The award sponsored by Infineon Technologies wireless business unit, which has turned into Intel Mobile Communications GmbH, was the access to a 28nm CMOS node. For a university research group this early access to an advanced CMOS node is almost invaluable. The first prototype has already delivered good results for a broadband OFDM signal and provides the base for further exploration of digital centric transmitters. A fourth chip implementing different

approaches for the output stages has been taped out already. Due to the digital centric nature of the design this chip will provide a verified design base for tape out of the 28nm test chip.

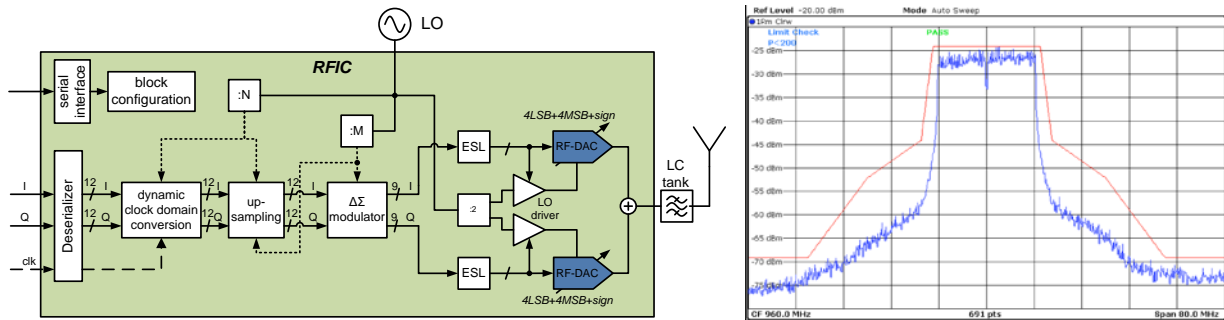

Figure 2-14: IQ RF DAC based design

Virtual RF Prototypes: The complexity of today's RF transceivers and RF macros requires a comprehensive verification of the overall functionality. Digital assisted RF techniques are based on sophisticated smart control and calibration algorithms. Their function has to be ensured based on the pre-tape out design data base in order to realize a first time functional design. Different HDL based methods have been used and evaluated within the UMIC RF test chip designs. The special requirement of the RF carrier involved prohibits the use of conventional AMS modelling techniques. VerilogA and Verilog AMS are still solving a set of differential equations resulting in an almost impossible high number of sampling points in order to just cover the RF carrier over the required system time. A SystemC virtual RF prototyping methodology has been developed, which generates a RF signal flow model directly from the Cadence Analog Artist design data base. The resulting SystemC code can be used in any suitable digital centric design environment allowing the verification of digital assisted RF architectures or the overall verification of an overall wireless SoC implementation.

Power Amplifier: Typically, for each communication standard and frequency band, which the mobile communication device supports, a dedicated PA is needed. Consequently, approaches were investigated on the design of PAs which not only can be implemented in standard CMOS, but which eventually can also cover more than a single communication band with a minimum amount of components. Both wide- and multiband PAs were investigated and successfully designed in standard 90 nm CMOS technologies. By adopting new design approaches for the on-chip load transformation network it was possible to demonstrate a compact wideband class-E PA design covering the 1.8 GHz to 2.9 GHz range.

A flexible energy-efficient multiband CMOS PA core was also demonstrated by exploiting the capability of CMOS of co-integrating digital and mixed-signal circuitry alongside with the analogue blocks. Combining a reconfigurable load coupling network with a novel wideband driver stage design demonstrates both the flexibility demanded by PAs in multiband terminals and the energy-efficient operation necessary in handheld devices [Aref2011].

A novel power amplifier class of operation – class O – which is optimised for nanoscale CMOS technology addresses both linearity and voltage stress issues simultaneously due to a patented circuit architecture [Aref2012]. Very low voltage stress can be seen in simulations and measurements on the active devices even at output power levels exceeding 1 W. A class-O demonstrator circuit has been designed in 130 nm CMOS and the results were presented at the

ISSCC 2015. It could be shown that a class-O PA in 130 nm CMOS is able to comply with the spectral emission masks for both 3G and 4G signals at elevated power levels of more than 27 dBm without the requirement of predistortion at 2.3 GHz.

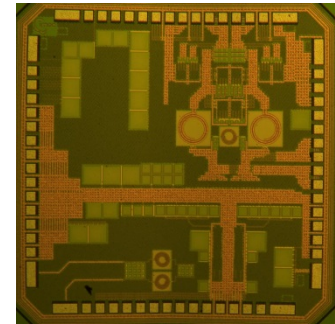

Figure 2-15: Wideband class-E power amplifier

2.3.2.2 Nucleus: A novel application specific SoC design methodology

Digital SoC platform design for mobile user equipment requires the right balance between flexibility, cost, and efficiency. Since general-purpose programmable platforms and components are clearly too inefficient for mobile signal processing, application-specific architectures are mandatory. In turn, this demands for dedicated design methodologies. The Nucleus methodology [Ramakrishnan2009] conceived by the ICE institute team is based on the principle observation that platform design must be driven by critical algorithmic kernels (“Nuclei”) which appear in parameterized form across multiple signal processing applications. This raises three key issues: (1) What are the “proper” Nuclei and how to model them? (2) How to efficiently implement Nuclei as flexible hardware accelerators or processor-specific software? (3) How to integrate, program, and validate a platform using a “Nucleus library”? The major achievement and differentiator of Nucleus - when compared to other approaches followed worldwide - is the true co-design of new algorithms, architectures, and tools for complex heterogeneous multicore platforms. Similar research is performed by computer science experts to build systems based on kernels in general purpose applications [UCB2006]. UMIC provided the critical mass for this interdisciplinary research endeavour. Initially conceived for the PHY layer, Nucleus has been later successfully adopted in cross-disciplinary fashion also for novel MAC platform design (see also RA-A). Besides many important individual contributions in the domains of algorithms, architectures, and

tools, a major output of this flagship project is a complex Nucleus-based MIMO OFDM transceiver prototype that integrates silicon and FPGA prototypes together with advanced virtual prototypes within a uniform SystemC model.

Algorithms and Architectures

When studying the Nucleus concept in more detail, the first issue is the identification of the proper Nuclei. A Nucleus must be a processing intensive part of the transceiver algorithms since such parts determine reusability, throughput, latency, power/energy consumption and chip area. On the other hand, a Nucleus should be as generic as possible, i.e. represent a basic algorithm like an FFT rather than a specific function like a MMSE demapper because of the much higher reuse factor. Identified Nuclei are for example the aforementioned FFT, matrix operations [Rama-krishnan2011] and sorting operations.

Different implementations of a Nucleus, whether they are algorithmically different (e.g. radix-2, radix-4 FFT) different in processing (internal/external scaling, rounding/truncation) or in target (assembly code for a DSP, hardware accelerator), are denoted as flavours of this Nucleus. Each flavour description consists of the function code augmented by information for the mapping tool like the parameter set and range, I/O

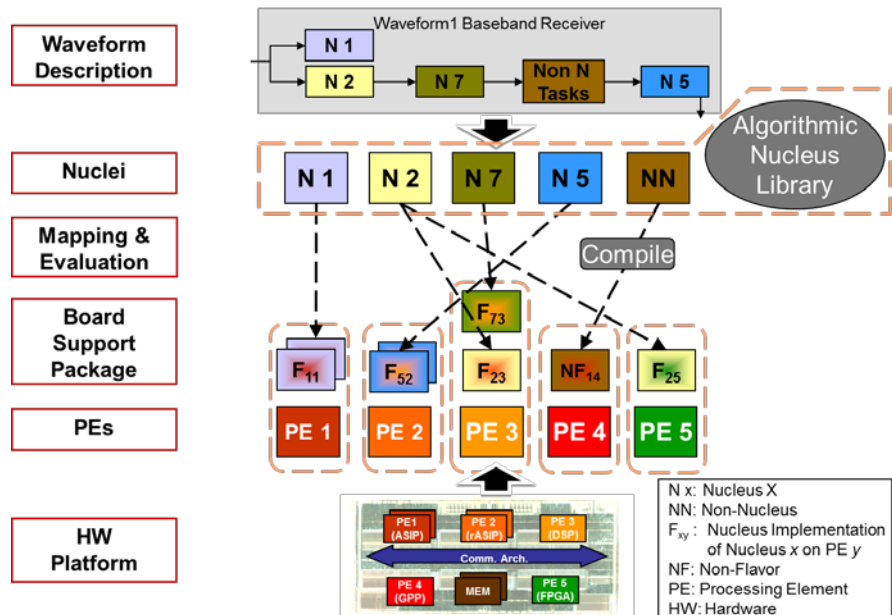

Figure 2-16: Nucleus based design flow

descriptors and performance information (instruction count, memory footprint, SNR loss). This approach enables a tool based mapping of the algorithmic model onto arbitrary processing elements – using “flavours” of the Nuclei in support packages. When for a Nucleus a flavour is not found in a support package it can simply be replaced by code compiled from the algorithmic model. The design flow is sketched in Figure 2-16.

To get a realistic proof of concept the Nucleus approach was successfully applied to a MIMO OFDM receiver (see Figure 2-17), comprising channel estimation, MIMO demapping, decoding and MAC. The flexibility requirements were realized by using different modes, different algorithms and different iteration concepts between the stages estimation, demapping and decoding as well as within decoding (for Turbo and LDPC codes) and by a flexible MAC. Note that another proof of concept of the Nucleus methodology is done as part of an associated European Union funded project where the physical and MAC layers of a MIMO-OFDM transceiver following 802.11a/n formats are mapped onto many-core platforms from different research groups (ST, IMEC).

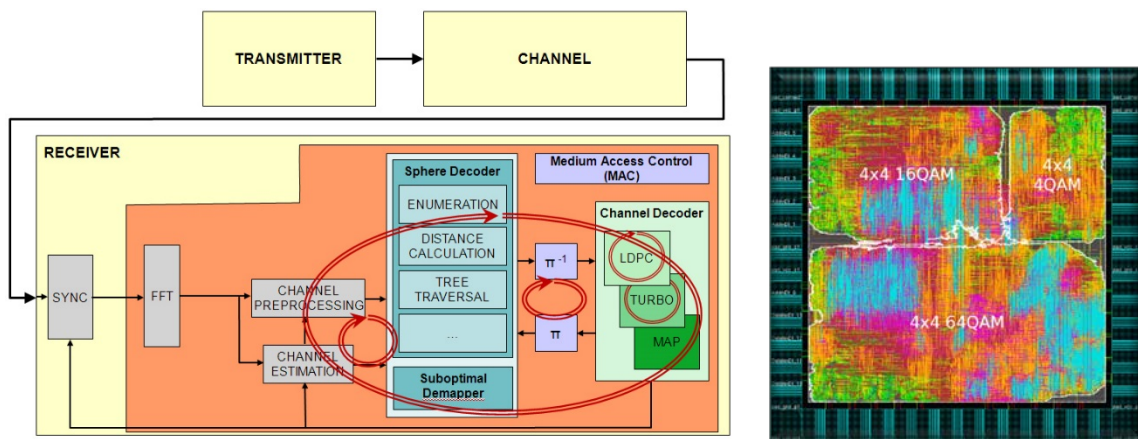

Figure 2-17: Iterative receiver functionality considered in the Nucleus project and layout of SISO sphere decoder ASIC (prototyped on UMC 90nm technology)

The results so far have demonstrated the advantages of the Nucleus concept. They also supported the argument that efficient platforms for high rates have to be heterogeneous, i.e. contain both general purpose (e.g. RISC cores) and application specific (e.g. ASIP, hardware accelerators) processing elements. The trade-off between flexibility (provided by more general purpose processing elements) and chip-area/energy efficiency (provided by more task-specific processing elements) was studied in more detail, initially for MIMO demappers in iterative OFDM receivers. In an optimum iterative approach the demapper accepts a priori reliability information (soft-input) and provides enhanced a posteriori reliability information (soft-output) and, thus, is denoted as SISO demapper. The optimum demapper is based on the MAP approach. To study the cost of flexibility several versions of such a demapper were implemented as dedicated hardware blocks with different levels of flexibility (configurability) on a single integrated circuit¹. This ASIC also

¹ The design was done in collaboration with the group of Helmut Bölcskei at ETH Zurich which has done ground breaking work in the implementation of MIMO demappers.

marked the world's first SISO single tree search sphere decoder [Witte2010]. It was used to verify the performance predicted by post-layout simulations and, in particular, to measure real power consumption for the different hardware configurations. The measurements were complemented by simulation based power consumption estimates for programmable solutions, i.e. an ASIP and a RISC based implementation. Since the energy efficiencies of the two processors are inferior to the configurable hardware solution by orders of magnitude, the higher inaccuracy of the simulation based power estimates does not invalidate the qualitative findings.

The next step towards a better understanding of iterative receivers was an ASIC (IteRx) which implemented a SISO sphere MIMO demapper together with a LDPC decoder in 65nm CMOS (see Figure 2-18). This ASIC was designed in collaboration with Andreas Burg (EPFL Switzerland), who provided the decoder. To match the throughput of demapping with decoding five demappers working in parallel were implemented [Borlenghi2012].

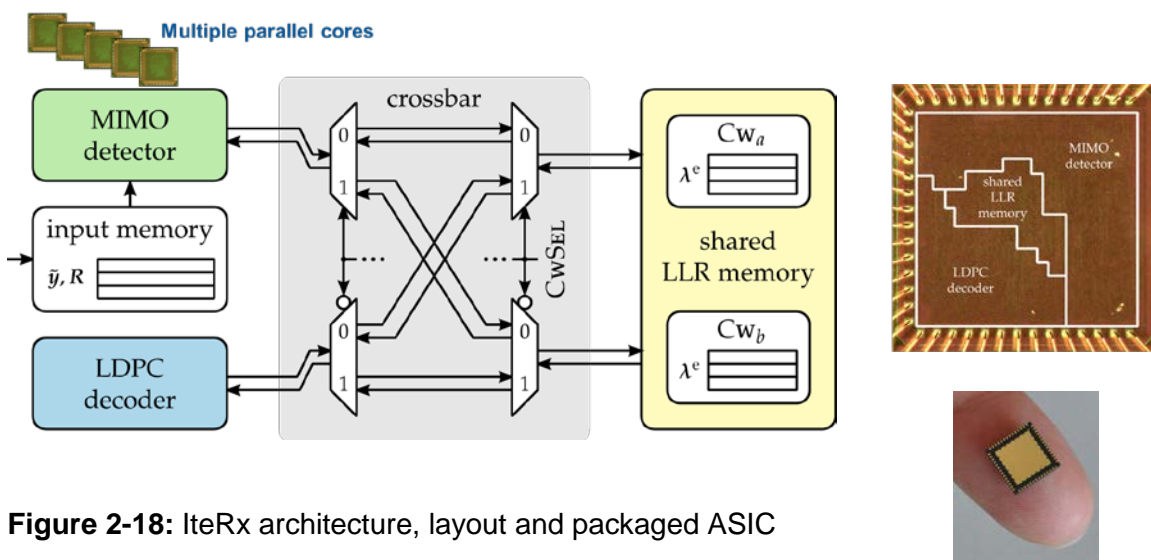

Figure 2-18: IteRx architecture, layout and packaged ASIC

Besides a number of new architectural solutions, measurement of performance and processing energy consumption of the actual ASIC revealed a new understanding of their relation. Key metrics for comparing the efficiency of implementation have been area (or gate count), throughput and energy (ATE). In many wireless systems the required throughput is specified by the standard, i.e. it represents a constraint rather than an optimizable performance measure. Therefore, our studies concentrated on gate count and, because of its importance for battery operated devices and for controlling heat dissipation of an IC, especially on processing energy. A key question is how to compare different implementations reasonably. Agreed and established measures for comparison are the gate count to achieve a particular throughput and the energy per task (e.g. per information bit, per pixel, etc.). These measures are adequate when comparing different

implementations of the same algorithm. They can be regarded as the “implementer’s view”. However, they ignore the algorithmic performance and flexibility. For example, in iterative receivers the number of iterations (and, thus, energy consumption) may be traded against bit error rate (BER) performance. Depending on the channel and the SNR a processor may run a suboptimal, simpler algorithm for the same error rate performance. Most wireless systems specify a performance limit, e.g. BER and/or frame error rate (FER) above a minimum SNR. Therefore, we have proposed to include this algorithmic performance limit as an additional constraint in the comparison. This has led to significant new insights on the cost of flexibility.

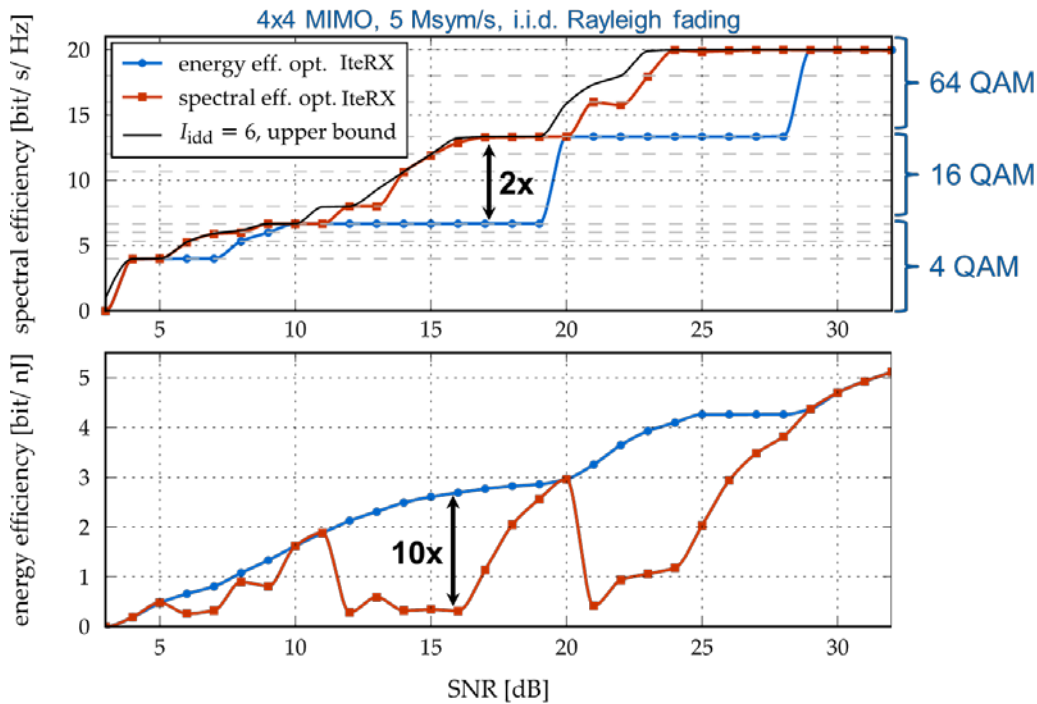

Figure 2-19: Spectral Efficiency vs. Processing Energy Efficiency

Figure 2-19 shows 2 different performance optimization goals. The red line represents the operating mode of the iterative receiver which yields the highest spectral efficiency. The upper subfigure shows the spectral efficiency while the lower subfigure shows the required processing energy per bit, i.e. the processing energy efficiency. In contrast, the blue line represents the operating mode with the highest processing energy efficiency (i.e. most information bits per nJ of processing energy). Obviously, this causes a loss in spectral efficiency. In conclusion, we have a trade-off that can be used to adjust the optimization goal depending on wireless network status and user data rate requirement vs. battery or on-chip temperature status.

System-level Design Tools

The design tools development as a part of the Nucleus methodology has focused on two major issues: Nucleus-aware *programming tools* for heterogeneous multicore SoC and *advanced simulation technologies* for virtual platforms.

While many international research activities in multicore programming focus mostly on the parallelization of sequential application software (e.g. [Mignolet2009, Thiele2011]), we have pursued a broader approach in the MAPS project [Leupers2010] with the following main differentiating features:

Programming model: Parallel platforms should obviously be programmed with parallel languages or formalisms. On the other hand, the freedom in creating new programming languages is practically limited by the huge amount of certified sequential legacy code. In order to resolve this key dilemma in multicore programming, the “C for Process Networks” (CPN) language was designed, that comprises both parallel communicating processes (according to the KPN semantics) as well as sequential code (according to the ANSI C semantics) inside processes.

Multitasking and timing constraints: Mobile terminals have to support more and more radio standards and multimedia codecs in various concurrent usage scenarios. These scenarios have to be executed under tight resource and timing constraints. CPN has been extended to cover such multitasking scenarios and to model various classes of timing constraints (hard/soft/non-real-time).

Heterogeneous target platforms: MAPS comprises novel code instrumentation technologies for dynamic application profiling. They allow to predict computation and communication latencies on heterogeneous platforms with application specific processing elements. This feature is used for computing optimized spatial and temporal task-to-processor mappings. The mapping also employs a clustering based sequential code partitioning technique for exposing more parallelism.

Nucleus-aware mapping: The critical kernels of applications are identified and predesigned as optimized, parameterized hardware or software implementations. They are instantiated from the Nucleus library and are invoked inside CPN specifications. MAPS treats Nucleus instances as black boxes and automatically computes the required interfacing (e.g. data conversions) during the mapping phase.

Altogether, the MAPS tools provide significantly higher productivity in programming of heterogeneous multicore architectures. The figure below illustrates the present situation. In contrast to traditional practices (“yesterday”), mostly based on C compiler-based programming of single-core targets, industry is facing huge issues (“today”), since existing sequential legacy code needs to be manually parallelized and mapped, which is both time-consuming and error-prone. MAPS enables (“tomorrow”) a more automated programming flow and leaves the choice of using C or CPN to the programmer, depending on his actual use case.

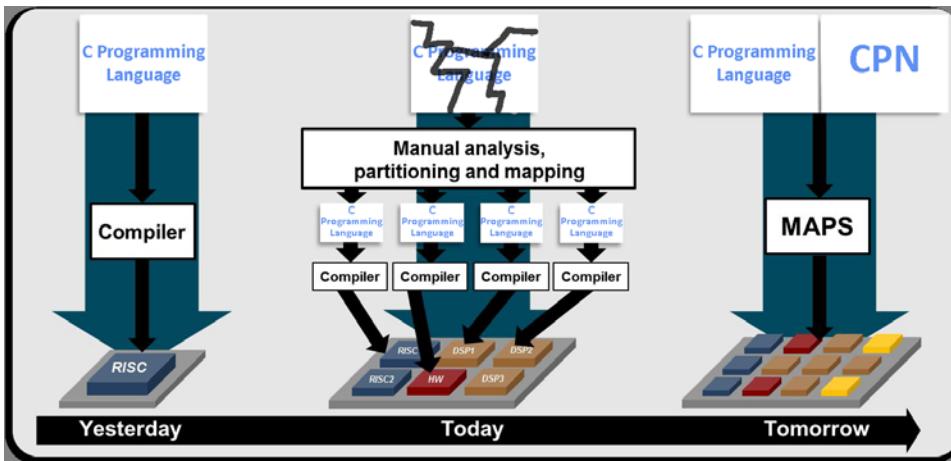

Figure 2-20: From single-core to multi-core programming

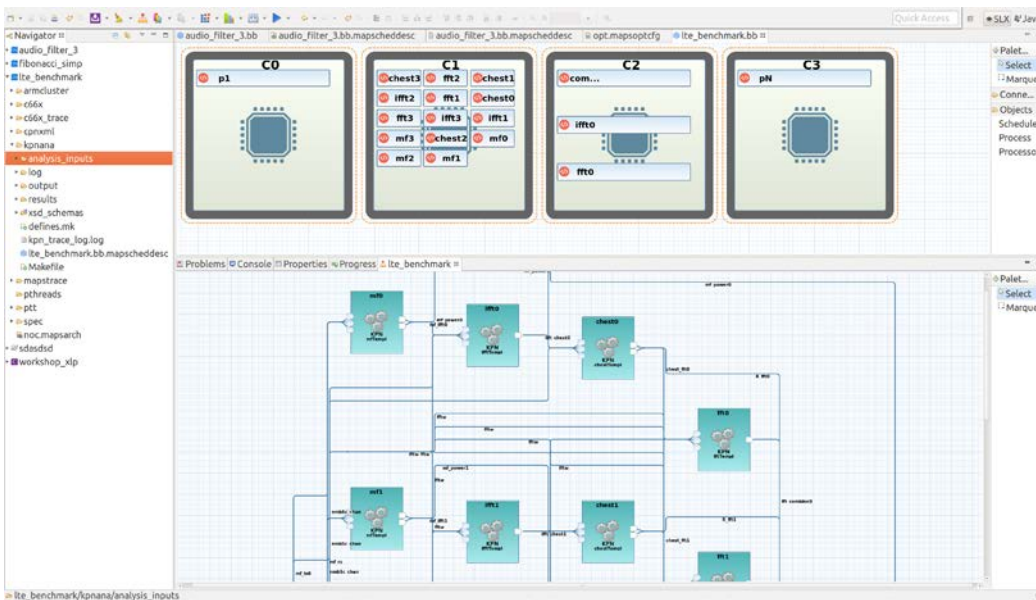

Figure 2-21: MAPS GUI

The MAPS flow has been successfully demonstrated for various targets, e.g. the UMIC-internal MIMO OFDM transceiver prototype, TokyoTech's TCT platform, and Texas Instruments' OMAP 35x. Next to this, several collaborations with partners from wireless and smartphone industries indicated significant speedup and energy savings for real-life heterogeneous multicore hardware platforms and applications. Currently, supported via an EXIST-Forschungstransfer fund from BMWi and venture capital, MAPS is being productized by the ICE spin-off company Silexica (www.silexica.com). As an example, the screenshot below shows Silexica's Eclipse based SLX Mapper product, which implements the spatial and temporal task to processor core mapping.

The tool can compute mappings optimized for performance or power automatically, but the programmer can also easily drag-and-drop tasks from the CPN processor network into the cores (C0-C3) of a target platform that is provided as an external XML model.



Figure 2-22: Virtual Platform of a Chumby wireless device

The Nucleus methodology also depends on virtual platforms for fast exploration, estimation, and validation. The major goal in this domain is to enable a trade-off between simulation speed and accuracy for highly complex SoC models [Leupers2011]. As traditional simulation technologies do not scale well, we have concentrated on two novel approaches:

Parallel SystemC simulation: SystemC has become the de facto standard in system-level modeling of digital SoC architectures. With the increasing use of multicore PC platforms as simulation

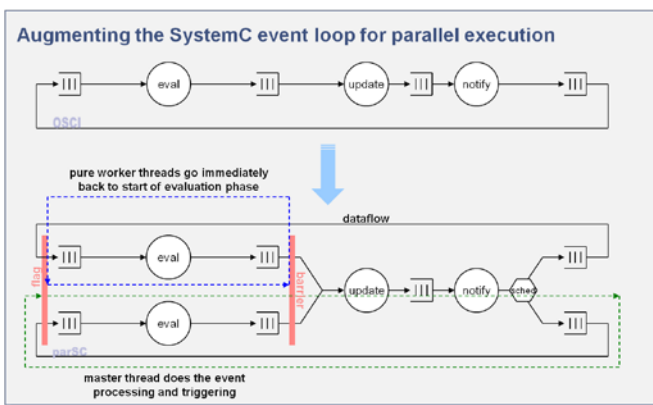

Figure 2-23: Parallel SystemC simulation

hosts, parallelization of SystemC simulation is a promising option for simulation speedup. In the context of Nucleus, a parallel version (“parSC”) of the SystemC simulation kernel has been designed [Schumacher10]. parSC parallelizes the evaluation phase of the SystemC simulation cycle (see Figure 2-23) and, depending on the number of available parallel threads inside the model, often achieves simulation speedups linear in the number of available host PC cores.

Hybrid simulation: A complementary approach for higher simulation speed is to raise the abstraction level of instruction set simulators (ISS’s), which form the heart of virtual Multicore platforms. Figure 2-24 characterizes the typical speed/accuracy trade-off in this domain, ranging from functional simulation down to cycle accurate simulation. The newly developed hybrid simulation (HySim) technology [Gao2008] permits dynamic toggling between (fast yet less accurate) functional/native code simulation and (slower, yet fully accurate) traditional ISS simulation. HySim has been fully integrated into state-of-the-art industrial virtual platform technologies, and a typical speedup of 10-100x over traditional ISS’s has been demonstrated for various embedded processor cores.

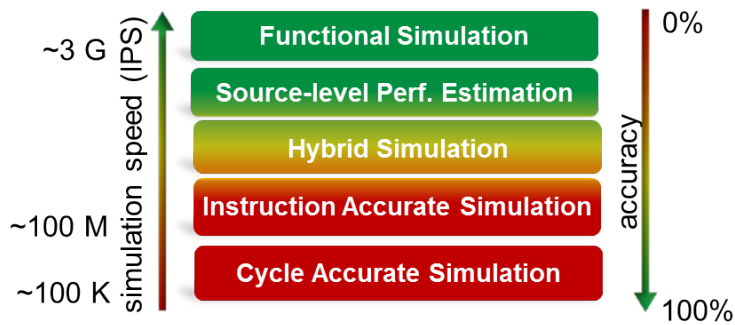

Figure 2-24: Speed and accuracy of simulation at different levels of abstraction

2.2.3.3 Publications

- Aref2011** A.F. Aref, A. Askar, S. Werner, D. Pozdniakov, D. Kalim, R. Negra, „Efficiency Boosting of Multilevel LINC Transmitter“, *2011 Asia Pacific Microwave Conference (APMC) Proceedings*, 2011
- Bormann2011** D. Bormann, S. Kählert, Lei Liao, M.-D. Wei, T.D. Werth, R. Wunderlich, S. Heinen, „A multiband multistandard notch filter LNA for LTE, WCDMA and GSM for SAW-less frontends“, *2011 Asiapacific Microwave Conference (APMC) Proceedings*, 2011
- Leupers2011** Leupers, G. Martin, N. Topham, L. Eeckhout, F. Schirrmeister, X. Chen: "Virtual Manycore Platforms: Moving Towards 100+ Processor Cores", *Design Automation & Test in Europe (DATE)*, Grenoble (France), Mar 2011
- Ramakrishnan2011** V. Ramakrishnan, G. Ascheid, M. Adrat, M. Antweiler, "SISO and MIMO Physical Layer on a Heterogeneous Multiprocessor Platform – Implementation and Mapping Exploration", *Software Defined Technical Radio Conference*, 2011
- Thiele2011** L. Thiele, L. Schor, J. Yang, I. Bacivarov: "Thermal-Aware System Analysis and Software Synthesis for Embedded Multi-Processors", *Design Automation Conference (DAC)*, San Diego, California, USA, Jun 2011
- Werth2011** T.D. Werth, C. Schmits, R Wunderlich, S. Heinen, "An Active Feedback Cancellation Technique for Blocker Filtering in RF Receiver Front-Ends", *IEEE Journal of Solid States Electronics*, vol. 45, no. 5, pp 989-997, 2010
- Aref2012** A.F. Aref, A. Askar, A.A. Nafe, M.M. Tafar, R. Negra, "Efficient Amplification of Signals with High PAPR Using Nove. Multilevel LINC Transmitter Architecture", *7th European Microwave Integrated Circuits Conference (EuMIC)*, 2012
- Leupers2010** R. Leupers, J. Castrillon: "MPSoC Programming using the MAPS Compiler", *Asia South Pacific Design Automation Conference (ASPDAC)*, Taipei (Taiwan), Jan 2010
- Ramakrishnan2009** Ramakrishnan, V., Witte, E. M., Kempf, T., Kammler, D., Ascheid, G., Meyr, H., Adrat, M., Antweiler, M.: "Efficient and Portable SDR Waveform Development: The Nucleus Concept", *Proc. of the IEEE Military Commun. Conf. (MILCOM)* (Boston, USA), Oct 2009

- Schumacher2010** C. Schumacher, R. Leupers, D. Petras, A. Hoffmann: "parSC: Synchronous Parallel SystemC Simulation on Multi-Core Host Architectures", *IEEE/ACM Int. Conf. on Hardware/Software Codesign and System Synthesis*, Scottsdale (USA), Oct 2010
- Witte2010** Witte, E. M., Borlenghi, F., Ascheid, G., Leupers, R., and Meyr, H.: "A Scalable VLSI-Architecture for Soft-Input Soft-Output Single Tree-Search Sphere Decoding", *IEEE Transactions on Circuits and Systems - Part II: Express Briefs*, no. 57, pp. 706-710, 2010
- Borlenghi2012** F. Borlenghi, E.M. Witte, G. Ascheid, H. Meyr, A. Burg, "A 2.78 mm² 65nm CMOS gigabit MIMO Iterative Detection and Decoding Receiver", *ESSIRC 2012*, Proceedings, pp. 65-682012.
- Mignolet2009** J.-Y. Mignolet, R. Baert, T.J. Ashby, et al.: "MPA: Parallelizing an Application onto a Multicore Made Easy", *IEEE Micro*, vol. 29, no. 3, Jun 2009
- Gao2008** L. Gao, K. Karuri, S. Kraemer, R. Leupers, G. Ascheid, H. Meyr: "Multiprocessor Performance Estimation Using Hybrid Simulation", *45th Design Automation Conference (DAC)*, Anaheim (USA), Jun 2008
- Karuri2008** Karuri, K., Chattopadhyay, A., Chen, X., Kammler, D., Hao, L., Leupers, R., Meyr, H., and Ascheid, G.: "A Design Flow for Architecture Exploration and Implementation of Partially Reconfigurable Processors", *IEEE Transactions on Very Large Scale Integration (VLSI) Systems*, vol. 16, no. 10, pp. 1281-1294, Oct 2008
- UCB2006** K. Asavonic et al.: "The landscape of parallel computing research: A view from Berkeley", <http://www.eecs.berkeley.edu/Pubs/TechRpts/2006/EECS-2006-183.html>, Dec 2006

2.2.4 Research area D (RA-D): Cross disciplinary methods and tools

2.2.4.1 Introduction

The objective of RA-D was to provide method and tool support for the analysis and design of mobile systems based on formal, mathematically rigorous underpinnings and on an interdisciplinary and cross-layer view on the analysis challenges. This general approach was highly successful and led to significant results, e.g., in fields like optimized protocol design, mobile security and data management, or software verification, most of which were initiated or devised by collaboration in RA-D and with the other areas.

2.2.4.2 Major research achievements: Performance analysis and simulation

This sub-area hosted one of the two new professorships in RA-D, the research group Mobile Network Performance led by Prof. Gross. Apart from his group, the results in this area were contributed by the groups of Profs. Katoen, Mähönen, Mathar, Seidl, Spaniol, and Vöcking.

Mobile Network Performance. The group has contributed to several key areas of performance evaluation for wireless networks. Most significantly, they derived a mathematical model in order to predict long-term cell capacities of multi-carrier systems with dynamic resource allocations [Gross2009] (Best Paper Award). For example, the model allows determining the number of acceptable VoIP flows in a cell only based on the average signal-to-noise ratios. This analytical model quantifies the multi-user diversity gain and was developed for noise- and interference-limited multi-carrier systems [Gross2010a]. In a next step, this model was extended to accurately coordinate transmit power levels between several cells in a cellular network taking into account the effect of multi-user scheduling gain.

A second major effort focused on improving capabilities of discrete-event based network simulation regarding the handling of computational demanding models as well as modelling hardware effects. Typically, events in network simulation are associated with a discrete point in time which makes it hard to identify independent events at run-time. A second problem of this modelling approach is that processing delays cannot be modelled directly (for example the latency coming from a complex FEC decoder or a more complex resource allocation algorithm). We developed a modelling and execution framework named HORIZON which expands events to durations, such that tasks are associated with a start time and end time [Kunz2010]. The underlying modelling assumption is that overlapping tasks are then inherently independent and can safely be offloaded for execution. HORIZON provides this modelling feature and implements a central scheduler in OMNeT++ which offloads constantly independent events depending on the future event set

[Kunz2011]. It helps us in the LTE context to investigate the dependence of complexity of the local scheduling algorithm and different interference coordination algorithms. Furthermore, HORIZON can account for energy consumption and naturally by the modelling approach also for processing delays.

In the completion funding period, fine-grained performance models for interference-limited LTE systems were elaborated [Parruca2013a]. These models were used to investigate algorithms for semi-static interference-control among a cluster of LTE cells [Parruca2013b].

In a further line of activity, protocol designs for hard real-time applications with extremely short latencies (~ 5ms) were investigated. This led to the prototyping of a system called EchoRing, accompanied by an analytical design method of the protocol based on probabilistic model checking [Dombrowski2013].

Distributed spectrum management. The group of B. Vöcking devised and analysed techniques for distributed spectrum management in mathematical models in close cooperation with RA-A. Inspired by approaches from evolutionary game theory, they investigated protocols that rely on a concurrent random sampling approach representing devices of different users by selfish agents. Interference on a channel is captured in a general fashion using abstract cost functions that monotonically increase in the number of agents on a channel. Having in mind the applicability of the protocols, the mathematical analysis was focused on protocols using a minimal amount of spectrum sensing: While pre-existing work relied on the comparison between different alternatives, our protocols require agents to know only the interference on the currently allocated channel [Fischer2008]. P. Mähönen's group complemented the mathematical analysis by simulations and laboratory experiments studying the performance gain and proving the practical applicability of the approach [Petrova2010].

For interference scheduling with respect to arbitrary (rather than stochastically generated) topologies, the corresponding optimization problem is known to be computational hard. Therefore the focus of the research lies on approximation algorithms. We made various significant contributions to this area. In [Kesselheim2011], the first algorithm was presented that achieves a constant-factor approximation with respect to capacity maximization. In an awarded article [Fanghänel2009], an instance-based measure of interference facilitating performance analysis of distributed contention resolution protocols was introduced.

The further work that was coming out from cross pollution of ideas and methods between B. Vöcking's and P. Mähönen's group, and later adding also M. Petrova's group to the discussion, exploited further the game theory based spectrum management methods. These led, for example, to the development for approximation algorithms for secondary spectrum auctions [Hoefer

2013], and work on the online capacity maximization in wireless networks [Fanghänel2013]. Furthermore, the work was extended to the limited feedback games such as minority games [Mähönen2008] and applying phase transition formalism to game theory based wireless analysis [Michalopoulou2012]. One of the most interesting results from all these works has been the confirmation that even very minimal feedback based games can be applied successfully to have powerful optimization algorithms for practical wireless communications problems.

Analysing QoS Aspects of Medium Access Protocols for Sensor Networks. The main goal of this research was to obtain a semantically sound analysis of quality-of-service aspects, in particular energy consumption, of wireless sensor networks (WSN) comprising battery-powered mobile sensors. The focus was on supportive protocols for gossip-based information dissemination. Our aim was to construct formal and precise models of these (complex) communication protocols that constitute the common ground for semantically sound discrete-event simulations as well as formal verification (e.g., model checking). Their analysis should provide suggestions for protocol improvements to lower the energy consumption.

Problems and Achievements: Formal models and analysis were conducted successfully for:

(1) A TDMA-based medium access protocol (gMAC for short) with a fully decentralized slot allocation. Our simulation-based analysis determined the number of active slots that optimizes the trade-off between low energy consumption and fast information dissemination for static and dynamic network configurations [Yue2010b].

(2) A leader election protocol for anonymous radio networks was analysed using probabilistic model checking. We investigated the quantitative properties of the original protocol such as the expected number of election rounds and considered a novel variant that consumes less energy (a reduction of 60%) and elects a process with larger energy with higher probability to be elected [Yue2010a].

(3) A variant of classical slotted Aloha in which the number of active TDMA slots is dynamically changed depending on the number of neighbours of a node. Based on a formal model, we analysed its energy consumption under the signal-to-interference plus noise ratio radio model. We proposed a protocol amendment by a simple dynamic power assignment scheme, and showed that this significantly reduces the energy consumption (30%) and speeds up the message propagation [Yue2011].

(4) Battery scheduling for a pack of batteries. Scheduling schemes like round-robin or choosing the best battery available provide a large improvement compared to a sequential discharge of the batteries. We determined by means of advanced model checking techniques the optimal off-line scheduling policy that maximizes the lifetime of the batteries. The schedules lead to lifetime improvements of up to 30% over round-robin scheduling [Jongerden2010].

Energy awareness of applications. Energy-awareness was a particular driving force for various developments which efficiently support data dissemination and data aggregation in mobile networks. A novel index-in-the-air schema for energy-efficient multimedia retrieval on mobile clients, RepAir, copes with error-prone wireless data transmission through adaptively scheduling the receiver's standby modes. Experiments demonstrate that RepAir successfully prolongs batteries' lifetime in mobile devices. For the use in heterogeneous networks of PDAs, mobile phones, and sensor nodes, a distributed k-center clustering algorithm for energy efficient summarization of data, Ediskco, was developed [Hassani2009]. This online algorithm supports noisy stream data and is aware of the limited processing, storage and power resources of sensor nodes. It particularly distributes the processing and the clustering of streaming sensed data efficiently among the nodes in the network.

For energy-efficient analysis of large-scale network data with heterogeneous structures of numeric and categorical attributes, new models and algorithms supporting sub-space clustering have been developed. Based on the novel density-unbiased clustering models DUSC and HSM which identify patterns in sub-spaces that are locally masked by noise attributes, several heuristics cope with the high computational complexity of the data analytics problem (EDSC, INSCY, DensEst). The insight that sub-space clustering may produce overwhelmingly large results lead to refined models (RESCU, OSCLU, ASCLU) that reduce the redundancy in the result sets and introduces a relevance model for the found clusters [Müller2009a]. Aside these fully automated algorithms, interactive concepts for the evaluation, visualization, and exploration of sub-space clusters have been developed and provided the vehicles to demonstrate the new models and algorithms on high-ranked international conferences. A further dissemination activity is the release of the open source framework OpenSubspace which comprises an implementation framework including state of the art algorithms for evaluation and comparison purposes [Müller2009b]. In the completion funding period, the challenge of analysing data with many attributes per object, e.g. sensors record a multitude of different measurements, was addressed. For these high dimensional data it is known that traditional clustering algorithms fail to detect meaningful patterns: mining the full-space is futile. As a solution we developed subspace clustering techniques that analyse arbitrary subspace projections of the data to detect clustering structures, thus leading to better aggregations and lower energy consumption of the mobile clients [Hassani2014].

2.2.4.3 Major research achievements: Reliability and availability

Contributions to this sub-area have come from the groups of Profs. Kowalewski, Spaniol, Thomas, and Wehrle.

The Impacts of Next Generation Wireless Networks on Transport Protocols. Future mobile services and applications have an ever-increasing demand for reliable high-speed communication. Wireless mesh networks (WMNs) provide a flexible technology for high-speed communication which can be deployed in areas where the installation of a (wired) infrastructure is impossible or too costly, but the advantages cannot be fully utilized due to protocol constraints. Especially the transport layer constituted a nearly unexplored area for this kind of networks. For instance, the performance of today's most popular reliable transport protocol, the Transmission Control Protocol (TCP), does not only depend on the access technology, but also on the frequency in use, interference level, the bandwidth available, and the employed routing techniques. The aim of this project was to develop reliable transport protocols for wireless networks, especially WMNs, which can be used in UMIC applications developed in RA-B.

To be able to tune and evaluate the developed protocols in real-world scenarios, a WMN testbed ([UMIC-Mesh.net](#)) was developed and set up. It is a hybrid testbed that consists of 51 real mesh nodes and a virtualized mesh environment with more than 300 nodes. [UMIC-Mesh.net](#) became a building block for several UMIC projects. Configuration and management tools were developed to ease the use of the network for other projects, as well as tools for visualizing measurement results. After set up of this testbed, the main task was to examine improvements to the transport protocol TCP and to evaluate them in different scenarios using [UMIC-Mesh.net](#). The main problem with TCP is its congestion control mechanism which interprets packet loss as a sign for congestion. There have been developed enhancements to TCP to deal with corruption loss as a non-congestion event, as well as with other factors influencing the performance of TCP because they can falsely activate the congestion control mechanism of TCP: delay spikes (e.g., due to handover), temporary connectivity disruptions and packet reordering [Zimmermann2008]. It was possible to show the impact of the enhancements due to evaluation in the testbed. All results from experiences in the setup of the testbed over tool design up to the TCP extensions were published at several conferences and workshops. Additionally, the newly developed mechanism for dealing with long connectivity disruptions was standardized by the IETF as RFC 6069 [Zimmermann2010].

Software Correctness and Quality. Software-induced failures or service level degradations represent a major concern in the development of increasingly complex mobile communication and

information systems and networks. Formal methods to avoid or identify and remove software defects are one possibility to deal with this challenge. The group of S. Kowalewski has investigated different approaches of applying formal methods to mobile systems. One aspect is the correctness of the run-time code of the terminal. Based on the work on model checking embedded microcontroller code, significant progress with respect to the size and complexity of the analysable code could be achieved by integrating model checking with static analysis. Different abstract domains for dealing with data variables were investigated which facilitate the verification of practically relevant arithmetical operations [Brauer2010; Brauer13]. This work also led to elegant alternatives of the analysis methodology, e.g., by performing existential quantification of variables using incremental satisfiability checking [Brauer2011]. In the completion funding period, the analysis methodology could be extended to application at run-time [Reinbacher2014].

The static analysis approach described above abstracts from quantitative time. When real-time properties need to be verified, different formal models need to be employed. In UMIC, an appropriate extension of the so-called Pi-Calculus was developed and successfully applied to mobile network protocols [Barakat2012a; Barakat2012b].

The work on formal analysis also led to constructive approaches for robust and reliable mobile computing. Patterns for load balancing and real-time scheduling for a mobile operating system were defined and deployed in prototype applications [Schommer2012; Kalkov2012; Kalkov2014]. These patterns were elements of a suggested comprehensive quality model for mobile software [Franke2012a] which takes into consideration not only functional correctness but also non-functional properties like maintainability and testability [Franke2012b].

For the analysis, we found as the most promising technique to investigate the extension of testing techniques by formal methods for complex software. In particular, when real-time requirements are involved, testing methodology can be improved by formal underpinnings. The focus of testing research in UMIC has been put on timed testing. By tight integration with the testing hardware, it was possible to provide a timed testing environment with improved responsiveness for a demanding practical use-case [Mitsching2011].

A very powerful approach to deal with consistency and correctness turned out to be symbolic execution, an approach to testing that works on the code of the software directly, without an intermediate model, and that allows for high coverage in test cases. While this technique is not as powerful as model checking itself, it shares a lot of features with model checking. The main advantage is that there is a tool for symbolic execution called Klee that can readily be used for protocol software written in C.

We have extended symbolic execution to distributed symbolic execution, which allows to debug protocol software in a communication network context. Using a tool called KleeNet, we were able to show that this technique is useful to find errors in protocols [Sasnauskas2010]. One problem is

however still the efficiency of the algorithm. Extending the approach of Klee for sequential execution to distributed algorithms causes an exponential blow up in the number of nodes involved in the communication. In an improved version of KleeNet we were able to improve its efficiency.

2.2.4.4 Major research achievements: Security and privacy

The second professorship, IT Security, led by Prof. Meyer, was established in August 2008 and built the main core of this sub-area. Further contributions were provided by the groups of Profs. Ascheid, Mathar, and Wehrle.

IT-Security. The research group IT-Security was established in August 2008 and is led by Prof. Dr. Ulrike Meyer. Within the UMIC Research Centre, the IT-Security group focused on privacy-preserving applications on mobile devices and security wireless mesh networks. In the area of fair and privacy preserving application, a new Java library for homomorphic crypto systems was designed and implemented. In addition, a proof-of-concept implementation of the fair and privacy-preserving iPhone app *Appoint* for privacy-preserving scheduling of a meeting between two parties was implemented and evaluated [Mayer2011]. This is the first implementation of a secure multi-party computation protocol ever implemented on a smartphone. In addition, the group for the first time solved the problem of reconciling ordered inputs in a fair and privacy preserving manner in a newly designed multi-party protocol [Neugebauer2010]. In the project on wireless mesh networks the group worked on bootstrapping security associations for key management in wireless mesh networks [Egners2010]. In addition, the group worked on several smaller projects related to RFID-security [Braun2010], secure time synchronization, the security of URL shortening services, and the development of a security framework for the UMIC HealthNet project [Barnickel2010].

Based on her UMIC-funded research work, Prof. Meyer was able to secure two research grants one funded by DFG and the other one funded by BMBF. The DFG-funded project is carried out in cooperation with the Stevens Institute of Technology in Hoboken, New Jersey. The goal of the project is to develop fair and private applications in the area of policy reconciliation. In the BMBF project ASMONIA the group of Prof. Meyer develops new methods for anomaly-based malware detection on mobile devices and new approach for client honeypots targeted at the collection of mobile malware. In addition, Prof. Meyer was able to establish research and development contracts with Nokia Siemens Networks (botnet monitoring in mobile telecommunications), the Netherlands Police Agency (further development of a botnet monitoring tool), as well as Siemens AG (bootstrapping security associations in M2M scenarios).

Transparent, Seamless and Secure Roaming for (Ultra) Mobile. IP-based systems mobility support is still an unsolved problem of the internet protocol suite, especially in combination with security features like access control and user authentication. Efficient mobility support requires short handover times while access control and authentication require additional protocols and cryptographic processing. Realizing security as add-on for mobility protocols can considerably prolong the delay for re-establishing the communication.

The goal of this project was to drive the software development of a system that integrates mobility signaling with authentication and access control measures. This integration can considerably shorten handover delays and leads to better user experience [Heer2008].

Funding for this project consisted of HiWi workers to aid the development and maintenance of a prototype for Wi-Fi handovers with integrated authentication. The funding provided the basis for a stable and efficient solution for a combined mobility and authentication system. The system extends the Host Identity Protocol (IETF RFC 5201) to achieve end-to-middle authentication during mobility events. The prototype is part of a decentralized large-scale Wi-Fi system, the Peer-to-Peer Internet Sharing Architecture (PiSA). PiSA provides seamless roaming for groups of users. The prototype is functional and was presented at several occasions (UMIC day Oct. 2009, RWTH Wissenschaftsnacht Nov. 2009, RWTH transparent Jan. 2010). Since then, the prototype was constantly extended and refined [Heer2010]. The approach was successfully adopted by the IETF for standardization in the HIP and HIP Cert internet standards.

2.2.4.5 Publications

- Barakat2012a** Barakat, K., Kowalewski, S., and Noll, T., "A Native Approach to Modeling Timed Behavior in the Pi-Calculus", in *Proc. 6th International Symposium on Theoretical Aspects of Software Engineering*, 2012, IEEE Computer Society, pp. 253-256.
- Barakat2012b** Barakat, K. and Kowalewski, S., "Modeling and Verification of Network Protocol Specs using Timed Pi-Calculus", in *Proc. The 4th International Workshop on Mobile Computing and Networking Technologies 2012 (WMCNT-2012)*, Saint-Petersburg, Russia, 2012, IEEE Press, pp. 735-742
- Barnickel2010** J. Barnickel, H. Karahan, U. Meyer: "Security and Privacy for Mobile Electronic Health Monitoring and Recording Systems", *IEEE International WoWMoM Workshop on Interdisciplinary Research on E-Health Services and Systems*, Jun 2010
- Brauer2010** J. Brauer, A. King, S. Kowalewski. Range Analysis of Microcontroller Code using Bit-Level Congruences. *Proc. Formal Methods for Industrial Critical Systems (FMICS 2010)*, Antwerp, Belgium, 2010, vol. 6371 in *Lecture Notes in Computer Science*, Springer, pp. 82-98
- Brauer2011** J. Brauer, A. King, J. Kriener. Existential Quantification as Incremental SAT. *Proc. 23rd Conf. Computer Aided Verification (CAV 2011)*, LNCS 6806, pp. 191-207, 2011

- Brauer2013** Brauer, J., King, A., and Kowalewski, S., "Abstract interpretation of micro-controller code: Intervals meet congruences", *Science of Computer Programming. Methods of Software Design: Techniques and Applications*, vol. 78, issue 7, pp. 862-883, 2013
- Braun2010** M. Braun, U. Meyer, S. Wetzel: Efficient Mutual Authentication for Multi-Domain RFID Systems Using Distributed Signatures, WISTP'10, April 2010 (WISTP'10 Most Innovative Technology-Related Paper Award)
- Dombrowski2013** C. Dombrowski, H. Yue, J. Katoen and J. Gross, "EchoRing – Design and Evaluation of a Wireless Protocol for Hard Real-time Applications", Research Talk VDE ITG Fachgruppe 5.2.1, Osnabrueck, Germany, September 2013.
- Egners2010** A.Egners, U. Meyer: Wireless Mesh Network Security: State of Affairs, 6th IEEE LCN SICK'10, October 2010
- Fanghänel2009** A. Fanghänel, T. Kesselheim, and B. Vöcking. Improved Algorithms for Latency Minimization in Wireless Networks. In Proc. of 36th International Colloquium on Automata, Languages and Programming (ICALP), pp. 447-458, 2009. (Best Paper Award, ICALP Track C)
- Fanghänel2013** A. Fanghänel, S. Geulen, M. Hofer, B. Vöcking, "Online capacity maximization in wireless networks", 2013, J. of Scheduling, vol. 16, iss. 1, pp. 81-91
- Fischer2008** S. Fischer, P. Mähönen, M. Schöngens, and B. Vöcking. Load balancing for dynamic spectrum assignment with local information for secondary users. In Proc. Symp. Dynamic Spectrum Access Networks (DySPAN), 2008
- Franke2012a** Franke, D., Kowalewski, S., and Weise, C., "A Mobile Software Quality Model", in *Proc. 12th International Conference on Quality Software (QSIC)*, 2012, IEEE Computer Society, pp. 154-157.
- Franke2012b** Franke, D., Kowalewski, S., Weise, C., and Prakobkosol, N., "Testing Conformance of Lifecycle-Dependent Properties of Mobile Applications", in *Proc. 5th International Conference on Software Testing, Verification and Validation (ICST)*, 2012, IEEE Computer Society, pp. 241-250.
- Gross2009** J. Gross, "Admission Control based on OFDMA Channel Transformation," in Proc. 10th IEEE International Symposium on a World of Wireless, Mobile and Multimedia Networks (WoWMoM), Kos, Greece, June 2009
- Gross2010a** J. Gross and M. Reyer, "Performance Prediction for OFDMA Systems with Dynamic Power and Subcarrier Allocation," *Journal Computer Communications*, Amsterdam: Elsevier, ISSN: 0140-3664, 2010
- Hassani2009** Hassani M., Müller E., Seidl T.: EDISKCO: Energy Efficient Distributed In-Sensor-Network K-center Clustering with Outliers. Proc. ACM SIGKDD Int. Workshop on Knowledge Discovery from Sensor Data (SensorKDD): 39-48, 2009
- Hassani2014** Hassani M., Kim Y., Seungjin Choi, Seidl T.: Subspace Clustering of Data Streams: New Algorithms and Effective Evaluation Measures (JIIS) *Journal of Intelligent Information Systems - Volume 42*. P.1-17 (2014)
- Heer2008** T. Heer, S. Götz, E. Weingärtner, K. Wehrle. Secure Wi-Fi Sharing at Global Scales, In Proc. 15th IEEE Int. Conf. on Telecommunication (ICT), St. Petersburg, Russian Federation, June 2008
- Heer2010** T. Heer, R. Hummen, N. Viol, H. Wirtz, S. Götz, K. Wehrle, Collaborative Municipal Wi-Fi Networks - Challenges and Opportunities, Proceedings of the Sixth IEEE PerCom Work-shop on Pervasive Wireless Networking (PWN 2010), Mannheim, Germany, April 2010
- Hofer2014** M. Hofer, T. Kesselheim, B. Vöcking, "Approximation algorithms for secondary spectrum auctions", *ACM Transactions on Internet Technology*, 2014, vol. 14, iss. 2-3

- Jongerden2010** Marijn R. Jongerden, Alexandru Mereacre, Henrik Bohnenkamp, Boudewijn R. Haverkort, and Joost-Pieter Katoen. Computing Optimal Schedules for Battery Usage in Embedded Systems. *IEEE Transactions on Industrial Informatics*, 6(3):276–286, 2010.
- Kalkov2012** Kalkov, I., Franke, D., Schommer, J. F., and Kowalewski, S., "A Real-time Extension to the Android Platform", in *Proc. 10th International Workshop on Java Technologies for Real-time and Embedded Systems (JTRES)*, 2012, ACM, pp. 105-114.
- Kalkov2014** Kalkov, I., Gurghian, A., and Kowalewski, S., "Predictable Broadcasting of Parallel Intents in Real-Time Android", in *Proc. 12th International Workshop on Java Technologies for Real-time and Embedded Systems (JTRES)*, 2014, ACM, pp. 57-66.
- Kesselheim2011** T. Kesselheim. A Constant-Factor Approximation for Wireless Capacity Maximization with Power Control in the SINR Model. In *Proc. Of the 22nd ACM-SIAM Symposium on Discrete Algorithms (SODA)*, pp. 1549-1559, 2011
- Kunz2010** G. Kunz, O. Landsiedel, J. Gross, S. Götz, F. Naghibi, and K. Wehrle, "Expanding the Event Horizon in Parallelized Network Simulations," in *Proc. the 18th Annual Meeting of the IEEE/ACM International Symposium on Modeling, Analysis and Simulation of Computer and Telecommunication Systems (MASCOTS'10)*, Miami, USA, Aug. 2010
- Kunz2011** G. Kunz, M. Stoffers, J. Gross and K. Wehrle, "Runtime Efficient Event Scheduling in Multi-threaded Network Simulation," in *Proc. the 4th International Workshop on OMNeT++*, Barcelona, Spain, Mar. 2011
- Mähönen2008** P. Mähönen, M. Petrova, "Minority game for cognitive radios: cooperating without cooperation", *Physical Communications*, vol 2008, Iss. 2, pp. 94-102
- Mayer2011** D. Mayer, D. Teubert, U. Meyer, S. Wetzel: Implementation and Performance Evaluation of Privacy-Preserving Fair Reconciliation Protocols on Ordered Sets, In: *CODASPY*, Feb. 2011
- Michalopoulou2012** M. Michalopoulou, P.Mähönen, "Game Theory for Wireless Networking: Is a Nash Equilibrium Always a Desirable Solution?", *Proc. Of IEEE 23rd International Symposium on Personal, Indoor and Mobile Radio Communications*, 2012
- Mitsching2011** R. Mitsching, C. Weise, H. Bohnenkamp, F. Fiedler, S. Kowalewski. TripleT: Improving Test Responsiveness for High Performance Embedded Systems. *Proc. 4th IEEE Int. Conf. Software Testing, Verification, and Validation*, pp. 67-74, IEEE, 2011
- Müller2009a** Müller E., Assent I., Günemann S., Krieger R., Seidl T.: Relevant Subspace Clustering: Mining the Most Interesting Non-Redundant Concepts in High Dimensional Data. *Proc. IEEE Int. Conf. on Data Mining (ICDM)*: 377-386, 2009.
- Müller2009b** Müller E., Günemann S., Assent I., Seidl T.: Evaluating Clustering in Subspace Projections of High Dimensional Data. *Proc. Very Large Data Bases (PVLDB) 2(1)*: 1270-1281, 2009.
- Neugebauer2010** G. Neugebauer, U. Meyer, S. Wetzel: Fair and Privacy-Preserving Multi-Party Protocols for Reconciling Ordered Input Sets, *13th Information Security Conference (ISC)*, October 2010
- Parruca2013a** D. Parruca, M. Grysla and J. Gross, *Performance Models for LTE Systems under Proportional Fair Scheduling*, In *Proc. IEE VTC Fall 2013*, Las Vegas, USA, September 2013.
- Parruca2013b** D. Parruca, M. Grysla, H. Zhou, F. Naghibi, M. Petrova, P. Mähönen and J. Gross, "On Semi-Static Interference Coordination under Proportional Fair

- Scheduling in LTE Systems“, In Proc. of the European Wireless Conference 2013 (EW 2013), Guildford, Engand, April 2013.
- Petrova2010** M. Petrova, N. Olano, and P. Mähönen. Balls and bins distributed load balancing algorithm for channel allocation. In Proc. 7th Conf. Wireless On demand Network Systems and Services (WONS), 2010.
- Reinbacher2014** Reinbacher, T., Brauer, J., Horauer, M., Steininger, A., and Kowalewski, S., "Runtime verification of microcontroller binary code", in *Proc. Science of computer programming*, 2014, vol. 80, Elsevier, pp. 109-129.
- Sasnauskas2010** R. Sasnauskas, O. Landsiedel, M. Hamad Alizai, C. Weise, S. Kowalewski, K. Wehrle. KleeNet: Discovering Insidious Interaction Bugs in Wireless Sensor Networks Before Deployment. Proc. 9th ACM/IEEE Int. Conf. Information Proc. in Sensor Networks (IPSN 2010), Stockholm, Sweden, 2010.
- Schommer2012** Schommer, J. F., Franke, D., Lange, T., and Kowalewski, S., "Load Balancing for Cross Layer Communication", in *Proc. 36th Computer Software and Applications Conference Workshops (COMPSACW)*, 2012, IEEE Computer Society, pp. 476-481.
- Yue2010a** Haidi Yue, and Joost-Pieter Katoen. Leader Election in Anonymous Radio Networks: Model Checking Energy Consumption. In 17th International Conference on Analytical and Stochastic Modelling Techniques and Applications (ASMTA). pages 247–261. Volume 6148 of LNCS. 2010
- Yue2010b** Haidi Yue, Henrik Bohnenkamp, and Joost-Pieter Katoen. Analyzing Energy Consumption in a Gossiping MAC Protocol . In Measurement, Modelling, and Evaluation of Computing Systems and Dependability and Fault Tolerance (MMB/DFT). pages 107–119. Volume 5987 of LNCS. Springer-Verlag, 2010.
- Yue2011** Haidi Yue, Henrik Bohnenkamp, Malte Kampschulte, and Joost-Pieter Katoen. Analysing and Improving Energy Efficiency of Distributed Slotted Aloha. In 11th International Conference on Next Generation Wired/Wireless Advanced Networking (NEW2AN). Volume 6869 of LNCS. Springer-Verlag, 2011
- Zimmermann2008** A. Zimmermann, D. Schaffrath, A. Hannemann. Improving TCP's Robustness to Long Connectivity Disruptions. Proc. 20th IEEE Global Communications Conference (GLOBECOM' 08), IEEE Communications Society Press, 2008, pp. 5064-5069.
- Zimmermann2010** A. Zimmermann, A. Hannemann. Making TCP more Robust to Long Connectivity Disruptions (TCP-LCD). RFC 6069, Dec. 2010.

2.2.5 Impact of UMIC after the funding period

One of the objectives of UMIC was to increase the international visibility and quality of related research at RWTH Aachen University. Similarly it has been our goal to foster not only internal collaboration, but enable a growth of the international network of collaborative research. There are a number of wireless research centres in the world, which we have been able to recognize both as competitors and occasionally also as cooperation partners for UMIC. However, we believe that UMIC has grown to be quite unique in its wide-scope of research topics and its approach of tackling problems from Electrical Engineering and Computer Science and investigating them together under a mission driven research cluster. Bridging different research cultures and methodologies has not been easy, and never will be, but during the excellence funding the UMIC has built critical mass, trust, and understanding between different research fields that we believe is quite rare even on a worldwide scale.

As discussed above in this report, in the actual research projects and on the research area level we have had a number of research successes at the highest international level. Our visibility has increased steadily through publications, research visits, and presentations, e.g. in conferences or industry expos. One of the good examples on our success has been the capability to attract top-level conferences to Aachen, something that is not easy for small non-metropolitan town to achieve normally; for example UMIC was helping to co-organize IEEE DySPAN 2011 conference in Aachen. The conference gathered virtually all the major cognitive radio groups in Aachen, which is just a one example of our increased attraction as an internationally recognized research cluster. A good example of a forthcoming conference is a major Information Theory Society meeting ISIT that will take place in Aachen in 2017.

Our competitiveness is furthermore shown and benchmarked by outsiders. As examples we can mention the facts that one of the principal investigators (Prof. Kobbelt) received an ERC Advanced Grant in 2013 and one of the former junior professors (Prof. Leibe) received an ERC Starting Grant in 2012. During the UMIC funding several of the principal investigators have become highly cited in their respective research fields with high h-indexes, examples being e.g. Prof. Kobbelt and Prof. Leibe in computer graphics, Prof. Jarke in information systems, and Prof. Mähönen in wireless networked systems.

Successful interdisciplinary application-oriented cooperation has been a key strength of UMIC. Our approach has been to have a strong, but focused, interdisciplinary team within the UMIC cluster. This team has been mostly coming from EE and CS communities at RWTH. However, we continued to embrace external collaborators outside EE and CS domains either as direct research collaborators with non-UMIC funding or as a possible technology transfer partners.

Researchers from the faculty of humanities were not directly participating in UMIC, but we have had fruitful project collaboration under the HumTec programme of RWTH. This programme is part of the institutional strategy of RWTH and fosters interdisciplinary research between the faculties of Engineering and of Arts and Humanities. A prominent example is the HUMIC project which studied acceptance as an integral element of the development and implementation of complex technical systems, using mobile communication networks as initial system-case.

Technology transfer was steadily increasing from UMIC projects and participating institutions. This was also laying the foundation for the sustainability of UMIC beyond excellence funding. One large additional funding and cooperation source for projects has been the participation in large EU funded Framework 7 projects that have paved the way towards future 5G systems. Contract research and license agreements have been conducted with SMEs as well as large vendors. As an indication of the scale of these successes, **third party funding** both in the RWTH CS department and EE faculty nearly doubled in the period of 2006-2010, and a large part of this success is due to UMIC. A part of technology transfer was also enabled with our close links with major standardization groups (e.g. participation in IETF and IEEE standardization work) and links towards spectrum regulators. The work in UMIC has also led to direct IPR and new companies generation; some of the computer graphics algorithms, developed in the context of UMIC projects, have been licensed by a Canadian digital media company that will commercialize them internationally. Similarly there are new start-ups founded by UMIC researchers such as Silexica that was founded in 2014, just to give an example on our continuing impact.

UMIC has built a strong link between our research and teaching activities. The critical mass build around research areas provided unique opportunities for graduate students both at M.Sc. and doctoral level to work in leading edge research projects. UMIC seminars and visiting lectures are generating increased educational opportunities for our students. New courses generated by junior professors and enhanced coordination between EE and CS have led to significant advances in our curriculum.

Overall, we believe that our major goals were successfully reached and the research groups individually and collectively are significantly more visible and better positioned in the end of the UMIC funding than in the beginning. UMIC continues to have impact on our research also after the funding period as the built research infrastructure, collaborative research network, and implemented structural changes have been now ingrained into our way of working.

In summary, we feel that we have reached both critical mass and quality level to be without any doubts nationally one of the top institutions in our field. Even internationally we should be seen to be among the very good research centres, one of the rare ones with such broad systems scope in its research, and some of our individual groups being internationally at the very top competitive level.

3 People

Before the staffing situation is described in more detail the concept of the centre must be briefly reviewed. It first consists of the UMIC research centre building which hosts new research groups established under UMIC funding, the centre administration, jointly used labs, and demonstrator and meeting facilities. Secondly, it comprises collaborating researchers hosted by the participating chairs. Since RWTH Aachen University is organized primarily in faculties (comparable to departments/schools) the research groups in the centre are also members of a faculty (either Computer Science or Electrical Engineering and Information Technology). This ensures that they are fully embedded in the university's self-government, in particular, with respect to strategy development and resource distribution.

3.1 Impact of the centre on academic positions

Due to the centre's concept described in the previous paragraph, its impact on academic positions has two aspects. On one hand the research of the centre has substantially increased the visibility of the research activities of the participating chairs and the centre research groups. This has led to an increase in third party funding both for new research projects and for technology transfer project. On the other hand several new research groups have been established under UMIC funding. For the first aspect it is difficult to exactly quantify the impact of UMIC. However, two exemplary figures indicate the importance and impact of the centre. Already in the first 5 years the participating chairs attracted additional party funding of 10 Million Euro per year on average. Over the total time of the cluster funding (2006-2014) third party funding of the faculty for Electrical Engineering and Information Technology grew from 13.5 Million Euro to 37.5 Million Euro (i.e. almost by a factor of 3). Since the increase in third party funding continued between 2012 and 2014 despite the ramp down of the cluster funding it obviously represents a sustained funding of the cluster activities.

Easier to quantify is, however, the impact of the research groups established under UMIC funding. The one group headed by an associate professor and the six research groups headed by junior professors (assistant professors) which were started based on UMIC funding are listed in Table 3-1. Except for one (Mobile Network Performance) the designations fully reflect the originally (i.e. for the first funding phase) proposed seven new research groups. From these seven groups four are now fully funded by the host university. For the remaining junior professorship a university funded tenure position is available. The junior professors heading the two remaining research groups accepted positions at internationally renowned universities (KTH Stockholm, NTU Singapore). Their teams were integrated into participating chairs of UMIC.

Table 3-1: UMIC funded new professor and junior professor led research groups

RA	Designation	Hosting Department	Continuation in RWTH Aachen
A	Information Theory and Systematic Design of Communication Systems	Electrical Engineering and Information Technology	University funded professorship (same designation)
A	Self-Organized Networks	Electrical Engineering and Information Technology	Tenured junior professorship
B	Mobile Network Performance	Computer Science	
B	Computer Vision	Computer Science	University funded professorship (same designation)
C	Mixed Signal CMOS Circuits	Electrical Engineering and Information Technology	University funded professorship (designation: High Frequency Electronics)
C	Multi-Processor Systems-on-Chip (MPSoC) Architectures	Electrical Engineering and Information Technology	
D	IT Security	Computer Science	University funded professorship (same designation)

A specific recruitment process for doctoral researchers was not set up. Due to the large number of students at RWTH Aachen University (Computer Science: from 2,000 in 2006 to 2,500 in 2014; Electrical Engineering and Information Technology: from 2,300 in 2006 to 3,900 in 2014) staffing was primarily based on own students complemented by unsolicited external applications. The international Master courses at RWTH Aachen arose as a very favourable means for attracting excellent international students. Admittance includes a selection process and courses as well as student projects provide an opportunity to identify excellent candidates for doctoral research.

The main impact of the cluster on the recruitment process concerns the professor positions. With cluster funding for the first time a in both departments (CS and EE) young high potential researchers were hired as junior professors with tenure opportunity. This program worked extremely well, all junior professors developed excellently (e.g. one of them was awarded a very selective ERC starting grant) and all (except for one which started later and is, therefore, still in qualification phase) reached tenured positions (see above). Because of the great success this career path option will be continued in both departments.

3.2 Promotion of early career researchers

One of the structural objectives of UMIC was and is to strengthen the promotion of early career researchers at RWTH Aachen University. We have successfully employed a multitude of support mechanisms towards different target groups. The graduate students working towards Ph.D. degree have benefited from increased research focus provided by UMIC and the available funding has allowed them to enter the research phase much earlier, without excessive teaching assistant

duties. The group spirit and interdisciplinary understanding was enhanced substantially by regular UMIC research group meetings, and students and postdocs have also beneficial links to other entities of RWTH such as different e DFG funded training schools. An English language based Master Programme in Communications Engineering has benefited from new courses provided both by new UMIC hired professors and UMIC principal investigators who have introduced new research oriented courses into the curriculum. Conversely, UMIC has benefitted from a steady stream of new Ph.D. and M.Sc. thesis students from this programme. The UMIC established visiting researchers' colloquium series and annual distinguished lecturer event have also provided a broader context, where students and postdocs had the opportunity to interact with distinguished visitors and top researchers from other institutions all over the world (e.g. visitors from Princeton, AT&T Labs, UC Berkeley, and MIT). These events, which did not exist earlier as systematically and centrally coordinated, have increased significantly the networking possibilities of early career researchers, and have provided an opportunity to compare their research and presentation skills to the competition from very top institutions.

Another highlight has been the systematic introduction of junior (assistant) professorships into our research culture. This approach has generated an avalanche of positive changes to our traditional German research structure. The independent junior groups have proven their value, and a new mentoring culture is rapidly gaining ground in the participating institutes to promote careers of young professors. Different approaches towards these groups have been followed. Computer science has mostly used the successful example of independent research groups (e.g., DFG Emmy Noether groups) as the basis of organization. Electrical Engineering has established a tenure track system for some of its junior professors in a similar fashion as in the USA, but adapting it to fit our own framework. All junior groups have been successful not only in research, but have also fostered a new research culture.

Through UMIC also a number of postdoctoral positions have been established. This is yet another mechanism to successfully support early career researchers: some of the postdoctoral positions have been offered to our best Ph.D. graduates providing the next stepping stone, and an even larger number has been recruited very competitively from external institutions. The postdoctoral assistants are closely mentored and supported by their respective hosting principal investigators both in research and career matters. The process has proven successful not only for early career researchers, but the injection of a larger number of postdoctoral researchers in our system has made strong positive changes in the general atmosphere among graduate students. Three postdoctoral researchers successfully completed their habilitation in the CS department (it should be noted that habilitation is not common in Electrical Engineering).

Naturally we have done our best to integrate both graduate students and new junior faculty members not only to UMIC, but to the larger framework of RWTH Aachen University. All the recent new programmes of the host university, including those funded by other DFG excellence programmes, are made available to UMIC members such as access to “Centre for Doctoral Studies” and “Aachen Centre for Young Researchers”.

3.3 Promotion of gender equality

Gender equality situation at the host university

RWTH Aachen University has implemented a comprehensive gender and diversity strategy which pursues the goal of realising structural equality at the university in all scientific areas and on all career levels. It was a strategic decision to assign the responsibility for this important issue to central university units. The “Integration Team – Human Resources, Gender and Diversity Management” (IGaD), established in 2007, coordinates the implementation, monitoring and evaluation of instruments.

The university has received several awards with respect to gender and equality. In 2011, the DFG honoured RWTH’s equality concept for the second time and ranked RWTH as one of Germany’s universities with most advanced level of gender policies.

A specific challenge in the research field of the centre is that the percentage of female students in EE in Germany has always been in the single digit range (i.e. <10%) and only grew in last few years (currently 16% at RWTH Aachen), in CS the percentage is slightly higher yet low as well. This leads to a shortage in female candidates qualified for a professorship. Globally the situation is only slightly better, attracting international candidates is loaded with the language barrier in everyday life. The junior professor track, however, had a positive impact as it opened an academic path to young talents leveraging the growth trend in the number of female students. As a very positive result, three of the seven professors hired with UMIC funding are female researchers (two of which are already tenured on university funding, the third most recently hired junior professor with a tenure option).

UMIC specific gender activities

From the beginning, one of the centre's aims was to work in cooperation with the gender institutions of the host university, the other centres and the graduate school, to find long-term, sustainable solutions to increase the participation of female researchers. Taking into account their gender activities as well as the recommendations of the DFG, PRAGES and the gender research programme "Frauen in der Spitzenforschung", we established several activities. Since the RWTH Aachen provides already a wide variety of gender measures at all career levels, we focused our efforts on the parts where additional activities made sense.

- a) The PRAGES guidelines recommend continuity in programme leadership. Therefore, a female gender equality appointee, Dr. Ute Müller, was nominated for the total UMIC funding period. Furthermore, a highly motivated team is very important for success. As a first step a gender team was established with focus on diversity and interdisciplinarity - members are female engineers from EE and CS with different academic positions (master students, postdocs, particularly with family) - to guarantee a realistic view of gender requirement, particularly work life balance. Since all gender team members worked voluntarily there was some fluctuation which brought new spirit and ideas into the team.
- b) To identify and evaluate the requested measures of female researchers, regular surveys – starting already in November 2006 – were established. Based on this feedback we have offered a series of different workshops, for example, "Has success sex?", "Women show their profile".
- c) The importance of role models regarding the recruitment of incoming junior female researchers is another part of our focus. In agreement with the university aims, UMIC offers a continuing education of teachers with focus on mathematical, physical, and computer science subjects. On the one hand these workshops present EE and CS as attractive degree courses for pupils with good mathematical knowledge because we have recognized that most of the teachers are not informed about the opportunities. On the other hand, by choosing female researchers as presenters both in front of the teachers and in school classes we provide role models for female pupils. As a result, the teachers as multipliers can inform pupils about the potentialities of studying EE or CS – in particular for women.

During the 1st phase of funding we have been in a learning process where measures had to be adapted to the needs of female researchers as well as to the financial and legal frameworks. Nevertheless, the UMIC gender activities were assessed very positively several times. In 2007 the UMIC gender team received the Brigitte-Gilles-Award from the RWTH. The establishing of a gender team with focus on gender aspects in the Faculty of Electrical Engineers and Department

of Computer Science was rated as very effective. The combination of analysis of needs and advancement measures for students and researchers was honoured as well as the close cooperation with the RWTH gender activities. Furthermore, the gender research programme “Frauen in der Spitzenforschung” noted very positively that the gender activities of the UMIC centre were above-average compared to the activities of other centres.

Table 3-2 shows that the percentage of female students, researchers and professors has grown significantly in the UMIC-participating departments. It is a success with significant contribution of the centre that the growth is over-proportional in the later career stages, moving towards a balance of percentages in all stages. Note that the percentage is already practically balanced between all groups in EE (17%, 15%, 15%)!

**Table 3-2: Students, doctoral researchers and professors 2006 and 2014
in the UMIC-participating departments**

Departments	Students (MSc/BSc/Diploma) (total / female (%))	PhD researcher (total / female (%))	Professors (total / female (%))
Electrical Engineering and Information Technology			
2006	2,657 / 9.8 %	297 / 7.4 %	27 / 0 %
2014	3,816 / 16.8 %	451 / 14.9 %	33 / 15 %
Computer Science			
2006	2,240 / 13.3 %	110 / 8.2 %	21 / 0 %
2014	2,358 / 14.6 %	265 / 12.5 %	25 / 8 %

4 Structures

4.1 Organisation and management of the centre

4.1.1 Steering committee and management

The centre was managed by a steering committee consisting of the UMIC coordinator and vice coordinator, the coordinators of the research areas and the coordinator for education, dissemination and training. The UMIC coordinator and the UMIC vice coordinator are running - supported by the office team – the day-to-day business. The steering committee has jointly decided on strategic issues, provided quality assurance together with the advisory board, and approved the assignment of the resources (i.e. budget and researchers) to the research groups based on research project applications and recommendations made by the area coordinators.

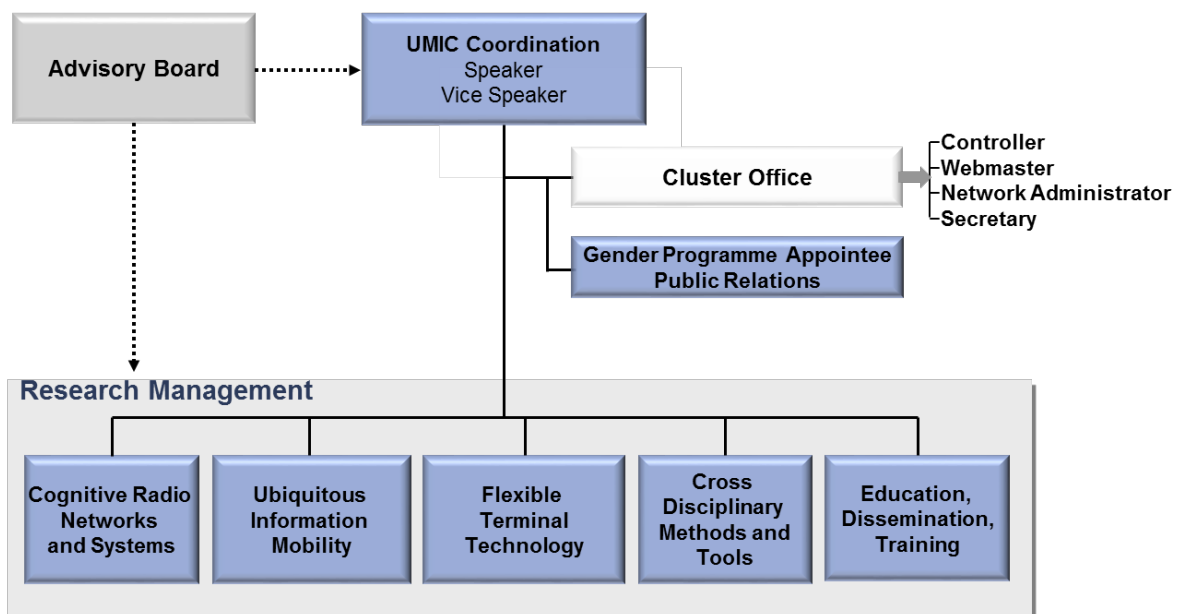

Figure 4-1: Management and organisation structure of UMIC

The steering committee members were elected by the members of UMIC, i.e. the principal investigators and the junior research group leaders (junior professorships) of UMIC. The members also participate in the regular strategy and research goal reviews. Thus, vision and goals were developed, shared and supported by all UMIC members.

The centre office team included controller, secretary, and an office manager, who coordinated public relations and meetings. The office manager was also the gender appointee.

The management structure has proven to be very effective.

Table 4-1: UMIC Steering Committee Members

Steering Committee @ Funding Start		Steering Committee @ Funding End	
Speaker	Prof. G. Ascheid	Speaker	Prof. G. Ascheid
Vice Speaker	Prof. O. Spaniol	Vice Speaker	Prof. M. Jarke
RA-A Coord.	Prof. B. Walke	RA-A Coord.	Prof. P. Mähönen
RA-B Coord.	Prof. M. Jarke	RA-B Coord.	Prof. L. Kobbelt
RA-C Coord.	Prof. T. Noll	RA-C Coord.	Prof. R. Leupers
RA-D Coord.	Prof. S. Kowalewski	RA-D Coord.	Prof. S. Kowalewski
EDT	Prof. R. Mathar	EDT	Prof. R. Mathar
Gender Equality	Dr. U. Müller	Gender Equality	Dr. Ute Müller

4.1.2 Advisory board

The advisory board has formed an integral part of our quality control and scientific steering processes. Due to the excellence status and our strong international links we were able to attract the very top international researchers and leading industry managers to form a strong board. It comprises four leading scientists with impeccable track record in relevant scientific fields and two seasoned industrial managers. We were also careful on building a group that has international members as well as persons coming from German speaking institutions. This has guaranteed that we have had members providing very unique and fresh opinions on organization and ambition levels, tempered by members who are knowledgeable on the traditions and regulatory framework that exists in Germany. We have found over the years that this combination has provided a perfect balance to challenge and to advice on scientific, technology transfer and public relations issues. The advisory board met regularly twice a year, and each meeting has been on average two days long. The agenda included presentations and demos not only by principal investigators, but also by junior researchers and graduate students, and closed sessions between advisors and UMIC steering group members. The extensive feedback was provided by the advisory board at the end of each meeting.

The process has been working beyond our expectations. The advisory board role has been growing with UMIC. It has provided us an important external and independent quality control group, which has been able to give invaluable feedback on our organization and research projects. The broad background of the advisory board members has also enabled them to interact in one-to-one mode directly with research area leaders to discuss more intricate scientific matters in their specialization domains. The chairperson of the advisory board was also acting as an important sounding board for the coordinator of the UMIC. Last but not the least, the advisory board members have been helping us to open doors, e.g. to NGMN pre-standardisation meetings and to becoming university advisor for NGMN.

Apart from the advisory and quality control role of advisory board we would like to emphasize that their regular visits and talks with junior researchers have had a tremendous impact on the UMIC spirit. Especially our graduate students and postdocs have appreciated comments, encouragement, and feedback from renowned researchers on their work; it has in a positive way, driven them to set goals higher.

4.1.3 Gender appointee

The gender research programme “Frauen in der Spitzenforschung” (which accompanies and supports the excellence initiative) noted very positively that at the end of the first excellence initiative funding period UMIC was the sole centre with a dedicated gender appointee and that this fact was very advantageous for the gender programme. Therefore this position was continued into the finishing funding phase.

4.1.4 Centre office

The tasks of the centre office are to provide the public relations and administrative support to the centre management. In the first funding phase it comprised a public relations manager, a financial controller and a secretary. The financial controller was hired for the originally proposed programme manager since financial planning, distribution, monitoring and reporting for the centre as well as for the junior professors required the appropriate expertise. Operational experience fully supported the need for this position. Programme management was then taken care of by the coordinator with support by the centre office.

4.1.5 Structural and administrative integration into the host university

The collaboration in the UMIC cluster was established as “Centre for Ultra High-Speed Mobile Information and Communication“ (UMIC Research Centre) under a cooperation agreement between the involved faculties (Faculty of Electrical Engineering and Information Technology, Faculty of Mathematics, Computer Science and Natural Sciences), the principal investigators of the centre and the centre-funded professorships (including junior professors). The chosen organisational form already had a proven track record at RWTH Aachen University. The centre is also a core activity of the profile area “Information and Communication Technology” of RWTH Aachen (see also Section 4.2).

The centre is a separate cost centre within the university. The funds were managed by its steering committee with support by its financial controller. Based on project approval the appropriate

funds were transferred to the corresponding entities (chairs, junior research groups, and partners). Documentation of the use of centre funds was handled by the financial controller in collaboration with the university's controlling department.

4.1.6 Public outreach, transfer activities

Public relations of UMIC included common activities like website and newsletter, an annual UMIC day with presentations by UMIC researchers and invited presentations, an annual open day at the UMIC research centre, and an annual UMIC Distinguished Lecture by an internationally renowned researcher. A particular focus of the transfer activities of UMIC were scientific community, industry and general public. The scientific community has specifically been addressed by more than 1,000 publications in peer reviewed conferences and journals, by special sessions in conferences and by attracting seven major conferences to Aachen (e.g. IEEE Peer-to-Peer Computing Conference 2008, IEEE DySPAN 2011). DySPAN 2011 was awarded to Aachen against competition of a major capital, thus, indicating the grown international recognition of UMIC researchers. The general public was addressed by various press releases and articles in leading German magazines (e.g. Bild der Wissenschaft, Welt).

Activities directed towards the industry community included active membership in NGMN, an organisation of the major mobile network operators worldwide, collaboration with an industrial development organisation (IKT.NRW) of the local state, demonstration of research results as exhibitor at major international events (e.g. Design Automation Conference in USA, Mobile World Congress in Spain), technology transfer in industry-funded projects and start-ups. Participation in the Mobile World Congress is particularly noteworthy. The event attracts a huge amount of visitors. Unlike other trade shows it is exclusively addresses professionals and, therefore, many relevant research and development managers visited our booth. A lesson learned from the first participation and accounted for in subsequent participations was that exhibits are most effective when they represent technology ready for transfer to industry. The investments paid off well in terms of newly identified technology transfer opportunities.

4.2 Relationship between the centre, the host university and the participating partners

4.2.1 Role of the centre within the host university

RWTH's research profile has moved towards an integrated interdisciplinary university by promoting interdisciplinary research and reinforcing the natural sciences. Key objectives driving this process were to shift the focus of the entire University to its core competencies, to empower all faculties to contribute significantly to this focus and to promote interdisciplinary cooperation between the faculties and beyond so that RWTH is enabled to tackle research topics of high societal and global relevance. One of the measures to strengthen interdisciplinary research was the identification and support of eight **profile areas**. Each profile area has a cross-faculty steering committee whose primary tasks are to establish collaboration structures in research fields of proven strength of RWTH Aachen University, to attract major project funding and to define a research road map for the area. Steering committees make recommendations on structural and financial measures in consultation with the rectorate, the dean's offices and the strategy board.

The profile area **Information & Communication Technology (ICT)** centres around the technologies required for ICT, like mobile device design, networked systems, the (mobile) internet and the extraction, distribution and security of information. Both hardware and software issues and, in particular, their interplay are covered. Research topics of the arts and humanities sciences, in particular, concerning the "information society" are brought into ICT research through HumTec and ERS. These are both measures to foster interdisciplinary research within the institutional

strategy of RWTH Aachen University, with HumTec focussing on linking arts and humanities sciences with the engineering disciplines.

The UMIC research centre is a major element of the strategy of the ICT profile area. The ICT Steering Committee members representing the EE and CS departments are all members of the UMIC research centre. Besides this formal integration aspect, the UMIC centre has led to a much more intense collaboration between the involved disciplines as demonstrated

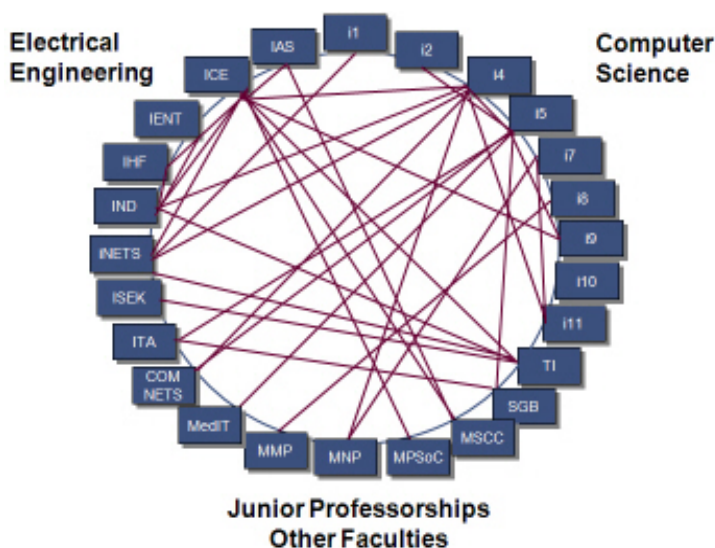

Figure 4-2: UMIC networking for the 2010 projects

exemplarily in Figure 4-2 for the 2010 projects. In addition, various formal and informal exchange opportunities have been set up by the centre to create a basis for sustainable collaboration.

4.2.2 Relationship to participating partners

The cluster proposal did not include other participating universities than RWTH Aachen University. It turned out, however, that it was more reasonable for some research aspects to work with partners from other universities than building up own expertise and infrastructure. Therefore, collaboration contracts including funding were set up starting 2009 and 2010, respectively, with the research group for Microelectronic Systems Design at TU Kaiserslautern and with the Electronic Measurement research lab at TU Ilmenau. Both collaborations were organized as research contract funded by the UMIC centre. They have led to a significant number of joint publications and a sustained collaboration, e.g. in joint DFG-funded projects.

An important relationship already mentioned before is the membership in NGMN, an organization of leading mobile network operators worldwide. Its “Members” can only be operators, mobile industry may become a “Partner” in NGMN and research institutions may be an “Advisor” to NGMN. Through the UMIC centre RWTH Aachen became one of the first “Advisors” of NGMN. The events and activities of NGMN on one side helped to initiate technology transfer projects with partners and members of NGMN but also gave early access to highly relevant information. Last but not least, it triggered collaboration with other advisors, like e.g. TU Eindhoven.

Towards industry the centre has aided to significantly increase industry funded technology transfer as well as successful application to EU-funded projects. It also enabled a new type of collaboration with some of the industry partners. In regular, typically semi-annual, joint workshops members of the UMIC centre presented research results and activities while in turn the industry partner shared his view on future developments and needs. The workshops covered pre-agreed topics in the areas of UMIC centre research, provided valuable directions for the centre research and triggered industry funded research projects.

4.3 Sustainability

4.3.1 Measures for sustainability

In the 1st funding phase a UMIC research centre building was erected, hosting centre office, junior professors, the UMIC professor on IT-Security with teams, various labs and demonstrator rooms with state-of-the-art equipment, and meeting rooms. Since then the university has further invested into facilities for the ICT-related groups. This includes an extension building for the CS

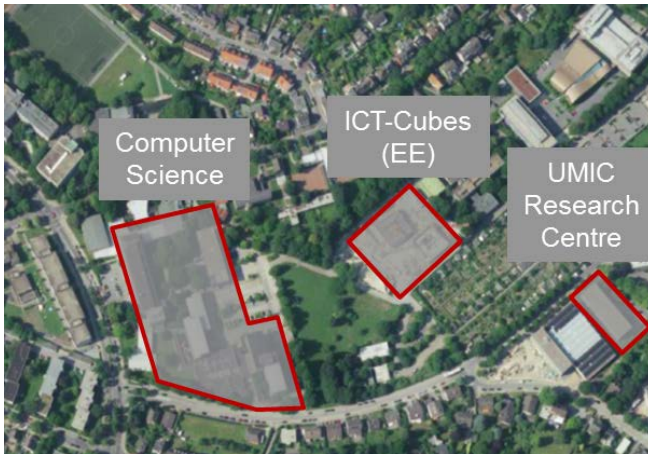

Figure 4-3: Location of ICT-related groups

Source: Bezirksregierung Köln, modified by RWTH Aachen
Data license see www.govdata.de/dl-de/by-2-0

Department and the "ICT-cubes" hosting most of the ICT-related chairs of EE (all of them also being members of the UMIC research centre). Now most of these groups are located within short distance as shown in Figure 4-3 (covering an area of approximately 600m x 400m). The UMIC research centre continues to host lecture, meeting and demonstrator facilities as well as labs for UMIC-related research and two of the professorships initiated by UMIC funding and their teams.

The second major measure to guarantee sustainability is the funding of additional human resources by the university. The IT-Security professorship and team started with UMIC centre funding are now funded permanently by the university. Three of the junior professors funded by the UMIC research centre now have tenured positions as professors with teams all funded permanently by the university. A further position is reserved as tenure option for the last hired junior professor to be funded by the university. Thus, the university has strongly invested and continues to invest strongly to sustain UMIC centre related research.

4.3.2 Sustainable behavioural impact of the UMIC research centre

Besides measures for sustainability, the UMIC cluster has caused both structural and human resource policy related changes which have a sustainable impact.

In the **structural domain** UMIC has been a success even beyond our own high expectations. Stated aims of the centre were to foster more integrated cooperation between participating chairs and institutes, to increase interdisciplinary research, and to lower the existing artificial barriers between two faculties (CS and EE). A number of different mechanisms were planned to achieve these aims, including having an interdisciplinary research area, acquiring a new UMIC research

centre building (funded by the host university), and fostering prototyping and demonstration activities. Our aim was also to encourage **a new culture of research work** mainly by recruiting and driving research strategically (based on vision and objectives yet maintaining scientific depth and allowing independence). The establishment of joint seminar series and exchange of research experience throughout UMIC as well as research-area-wide special research days have fostered **a new culture of cooperation, learning and debate**. The combination of these measures has led to the emergence of a new research culture and structure among all research groups and faculties active in UMIC. The number of interdisciplinary and cross-faculty projects has rapidly increased under the UMIC umbrella and we have been able to build a new research ecosystem between CS and EE groups. This has also had sustained structural effects. The UMIC steering board has often worked as a de facto cooperation group between CS and EE departments also in other than UMIC matters. This is tangible evidence on how important UMIC has been on building trust, transparency and a new structure to coordinate overall ICT research at the university. Consequently, UMIC has become a core activity of the university's profile area ICT and UMIC principal investigators have leading roles. The UMIC building and joint UMIC equipment have increased the efficient use of resources and created a UMIC team identity.

In the **"human resource domain"** we have been able to hire excellent new junior (assistant) professors. Three of these junior professors now have tenured professor positions funded by the host university. The junior professors have contributed strongly to the establishment of a new research culture and structure. Especially in the faculty of EE this has been a strong step towards introducing a tenure-track type of evaluation and career-path system for young researchers. Similarly UMIC has introduced a structured concept of postdoctoral research assistants in EE and CS faculties. As a part of UMIC funding we have also been able to establish a new professorship in IT-Security that has bridged a critical gap in the overall competence spectrum of CS/EE and is now funded by the university. The expansion and visibility of UMIC has not only supported the extension of our graduate student pool, but has also made a clear impact on the professionalization of their supervision and building a team spirit towards ambitious goals. We have also observed a significant improvement of our recruitment potential both in quantity and quality. Especially our capability to attract international students and postdocs, including female researchers, has improved, and we have reached a level that we would have been unable to reach without UMIC.

Both in the **structural domains and human resource policy domains** our achievements, visibility, equipment and structural changes have contributed strongly to our attractiveness to recruit and retain top talented persons. Our junior professors and postdocs are good examples on what

we have been able to achieve in recruitment. In retaining top talents, UMIC has been equally important; without the existence of the centre the university would have lost without doubt a few of our principal investigators to top national and international institutions.

4.3.3 Impact on the research profile

Since a full second phase of funding was not granted the proposed update of the research profile could not be implemented. Consequently, a reorientation of the research profile was required which was defined within the framework of the road map development of the ICT profile area. The implementation of this research profile is supported with university funds and still ongoing. It is planned that UMIC research will continue under two clusters, "Multimedia and Visual Computing" and "Digital Ambience". The road map of RWTH Aachen University's profile area Information and Communication Technologies (ICT) states:

The focus of one cluster is multimedia processing and visual computing. The topic has received a substantial push through the UMIC Cluster of Excellence, the current mobile multimedia activities are one of its major successes. Two of the UMIC participants received an EU advanced (Kobbelt) and an EU starter (Leibe) grant. In a future world, where information is one of the key assets, having a leading position in research on extraction of information from images and videos is of highest relevance. Another major topic of high future relevance, where RWTH already has a strong position to build upon, is augmented/virtual reality.

Another cluster addresses a topic that will affect and change our future life dramatically. It is labelled "Digital Ambience" thus expressing that we will have devices and systems everywhere. These systems will not only sense their environment, but communicate, decide and act, will be smart systems and/or work together to form a smart system on a higher layer and finally be a huge distributed smart system. Example application domains are smart city, smart energy, or smart mobility. Internet of Things (IoT) and Cyber Physical Systems (CPS) are two key fields addressed by this cluster. Research spans from embedded systems and tools to big data analysis. The cluster builds upon a strong position achieved through the UMIC Cluster of Excellence.

5 Overview of the Centre's Resources

5.1 Resources

5.1.1 Staff

Table 5-1 lists the total staff which has worked in the UMIC research cluster over the complete funding period. Since the second phase funding was primarily devoted to completion of ongoing doctoral research, new doctoral researchers were not funded by the centre. However, a few doctoral researchers (10) working in the centre but originally funded by other sources received (partial) funding by the centre to complete their doctoral research. A major difference between first and second phase was in the funding of the Junior Professor and the Professor position (IT-Security) originally funded by the centre. All these positions were funded by the university in the second phase. Further, three of the Junior Professors were promoted to tenured professor positions funded by the university and two of the Junior Professors accepted tenured professor positions at internationally renowned universities. The non-academic positions were reduced to two in the second funding phase. The corresponding support will be provided by the non-academic support teams of the speaker of the centre and of the profile area ICT.

Table 5-1: Staff (during complete funding period)

Staff	Funded by the centre	Funded by other sources
	Number of Persons	
Academic staff		
Professors	1	23
Junior professors	6	0
(Junior) group leaders	0	0
Postdocs (including rotational positions for clinicians)	9	4
Doctoral researchers	95	81
Research associates/other academic staff	0	0
Guest researchers	0	0
Non-academic staff	4	0

5.1.2 Infrastructure

The major infrastructure investment during the centre's set-up was the UMIC Research Centre building and, starting in the second funding phase, the construction of the "ICT Cube" (see also section 4.3.1). The UMIC building hosts the UMIC administration as well as meeting, seminar, lecture and demonstrator rooms and UMIC labs. Four of the six UMIC funded Junior Professors and the IT-Security Professor with their teams were located in the building as well. IT-Security and Computer Vision, one of the tenured professorships emerging from the junior professorships, will stay permanently in the UMIC building while the other groups move into the Computer Science building and into the ICT Cubes. Overall these investments have created an ICT campus within RWTH Aachen University and thus strengthened collaboration and research in this field substantially and sustainably.

Investments by centre funding have mainly been made into research equipment. In four labs state of the art equipment is available to all UMIC research teams. These labs comprise a wireless communication lab, a multimedia lab, an IT-Security lab and a MPSoC lab. The MPSoC lab, for example, provides simulation and measurement equipment for digital, mixed signal and RF designs.

6 Comments to the DFG

We would like to express our gratitude to DFG for excellently managing the program and the funding. Support was always given in a timely and very constructive manner. Also, the meetings of the coordinators and managers of the different excellence initiative activities organised by DFG were very helpful for networking, sharing of experiences and of best practices.

7 Appendix A

7.1 Most important publications of the centre

7.1.1 Journal publications

1. Riihijarvi, J.; Mähönen, P.; RübSamen, M., „Characterizing Wireless Networks by Spatial Correlations“, *IEEE Communications Letters*, vol. 11, issue 1, pp. 37-39, Jan. 2007
2. Feiten A. (Schmeink, A.); Mathar, R.; Reyer, M., “Rate and Power Allocation for Multiuser OFDM: An Effective Heuristic Verified by Branch-and-Bound”, *IEEE Transactions on Wireless Communications*, vol. 7, issue 1, pp. 60-64, Jan. 2008
3. Mathar, R.; Schmeink, A., “Proportional QoS Adjustment for Achieving Feasible Power Allocation in CDMA Systems”, *IEEE Transactions on Communications*, vol. 56, issue 2, pp. 254-259, Feb. 2008
4. Karuri, K.; Chattopadhyay, A.; Chen, Xiaolin; Kammler, D.; Hao, Ling; Leupers, R.; Meyr, H.; Ascheid, G., “A Design Flow for Architecture Exploration and Implementation of Partially Reconfigurable Processors”, *IEEE Transactions on Very Large Scale Integration (VLSI) Systems*, vol. 16, issue 10, pp. 1281-1294, Oct. 2008
5. Katoen, J.-P.; Zapreev, I.S.; Hahn, E.M.; Hermanns, H.; Jansen, D.N., “The Ins and Outs of the Probabilistic Model Checker MRMC“, *Performance Evaluation – Special Issue on Advances in Quantitative Evaluation of Systems – QEST 2009*, vol. 68, issue 2, pp. 90-104, Feb. 2009
6. Yifan Wang; Joeres, S.; Wunderlich, R.; Heinen, S., “Modeling Approaches for Functional Verification of RF-SoCs: Limits and Future Requirements“, *IEEE Transactions on Computer-Aided Design of Integrated Circuits and Systems*, vol. 28, issue 5, pp. 769-773, May 2009
7. Kensche, D.; Quix, C.; Xiang Li; Yong Li; Jarke, M., „Generic Schema Mappings for Composition and Query Answering“, *Data & Knowledge Engineering*, vol. 68, issue 7, pp. 599-621, July 2009
8. Bommès, D., Zimmer, H., and Kobbelt, L.: „Mixed Integer Quadrangulation“, *ACM Transactions on Graphics (SIGGRAPH 2009)*, vol. 28, issue 3, Aug. 2009
9. Fanghänel, A.; Kesselheim, T.; Vöcking, B., „Improved Algorithms for Latency Minimization in Wireless Networks“, *Automata, Languages and Programming, Lecture Notes in Computer Science*, vol. 5556, pp. 447-458, Springer, 2009
10. Pawig, M.; Enzner, G.; Vary, P., “Adaptive Sampling Rate Correction for Acoustic Echo Control in Voice-Over-IP“, *IEEE Transactions on Signal Processing*, vol. 58, issue 1, pp. 189-199, Jan. 2010
11. Werth, T.D.; Schmits, C.; Wunderlich, R.; Heinen, S., “An Active Feedback Interference Cancellation Technique for Blocker Filtering in RF Receiver Front-Ends“, *IEEE Journal on Solid-State Circuits*, vol. 45, issue 5, pp. 989-997, May 2010

12. Schmitt, L., and Meyr, H.: "A Systematic Framework for Iterative Maximum Likelihood Receiver Design", *IEEE Transactions on Communications*, vol. 58, issue 7, pp. 2035-2045, July 2010
13. Baier, C.; Boudewijn, R.H.; Hermanns, H.; Katoen, J.-P., "Performance Evaluation and Model Checking Join Forces", *Communications of the ACM*, vol. 53, issue 9, pp. 76-85, Sept. 2010
14. Huitema, G.; Kühne, R.; Meyer, U.; Ensing, H.; Zugenmaier, A.; Bibas, A.; Karasti, O.; Rumph, F.R.; Siljee, J., "Compensation: Architecture for Supporting Dynamicity and Negotiation in Accounting, Charging and Billing", *Computer Communications* vol. 33, issue 15, pp. 1823-1833, Sept. 2010
15. Witte, E.M.; Borlenghi, F.; Ascheid, G.; Leupers, R.; Meyr, H., "A Scalable VLSI Architecture for Soft-Input Soft-Output Single Tree-Search Sphere Decoding", *IEEE Transactions on Circuits and Systems II: Express Briefs*, vol. 57, issue 9, pp. 706-710, Sept. 2010
16. Gross, J.; Radmacher, F.G.; Thomas, W., "A Game-Theoretic Approach to Routing under Adversarial Conditions", *Theoretical Computer Science, IFIP Advances in Information and Communication Technology*, vol. 323, pp. 355-370, 2010
17. Kesselheim, T.; Vöcking, B., "Distributed Content Resolution in Wireless Networks", *Distributed Computing, Lecture Notes in Computer Science*, vol. 6343, pp. 163-178, Springer 2010
18. Schlich, B.; Brauer, J.; Kowalewski, S., "Application of Static Analyses for State Space Reduction to Microcontroller Binary Code", *Science of Computer Programming*, vol. 76, issue 2, pp. 100-118, Feb. 2011
19. Gross, J.; Reyer, M., "Performance Prediction for OFDMA Systems with Dynamic Power and Subcarrier Allocation", *Computer Communications*, vol. 34, issue 8, pp. 973-984, June 2011
20. Xiang Li; Wien, M.; Ohm, J.-R., "Rate-complexity-distortion optimization for hybrid video coding," *IEEE Transactions on Circuits and Systems for Video Technology*, vol. 21, issue 7, pp. 957-970, July 2011
21. Schmalen, L., Adrat, M., Clevorn, T., and Vary, P.: "EXIT-Chart Based System Design for Iterative Source-Channel Decoding with Fixed-Length Codes", *IEEE Transactions on Communications*, vol. 59, issue 9, pp. 2406-2413, Sept. 2011
22. van de Beek, J.; Riihijarvi, J.; Achtzehn, A.; Mähönen, P., "TV White Space in Europe", *IEEE Transactions on Mobile Computing*, vol. 11, issue 2, pp. 178-188, Feb. 2012
23. Rashed, K.A.N.; Renzel, D.; Klamma, R.; Jarke, M., "Community and Trust-Aware Fake Media Detection", *Multimedia Tools and Applications*, vol. 70, issue 2, pp. 1069-1098, May 2014
24. Wei, M.-D.; Kalim, D.; Erguvan, D.; Chang, S.-F.; Negra, R., "Investigation of Wideband Load Transformation Networks for Class-E Switching-mode Power Amplifiers," *IEEE Transactions on Microwave Theory and Techniques*, vol. 60, issue 6, pp.1916-1927, June 2012

25. Aref, A.F.; Negra, R., "A Fully Integrated Adaptive CMOS Multiband Multimode Switching-Mode Power Amplifier," *IEEE Trans. Microwave Theory and Techniques*, vol. 60, issue 8, pp.2549–2561, Aug. 2012
26. Campen, M.; Bommès, D.; Kobbelt, L., "Dual Loops Meshing: Quality Quad Layouts on Manifolds", *ACM Transactions on Graphics (SIGGRAPH 2012)*, vol. 31, issue 4, July 2012
27. Klein, D.; Radmacher, F.G.; Thomas, W., „Moving in a Network under Random Failures: A Complexity Analysis“, *Science of Computer Programming*, vol. 77, issue 7-8, pp. 940-954, July 2012
28. Geisler, S.; Quix, C.; Schiffer, S.; Jarke, M., "An Evaluation Framework for Traffic Information Systems Based on Data Streams". *Transportation Research Part C, Special Issue on Data Management in Vehicular Networks*, Volume 23, pp. 29–55, August 2012
29. Wang, T.; de Lamare, P.C.; Schmeink, A., "Joint Linear Receiver Design and Power Allocation Using Alternating Optimization Algorithms for Wireless Sensor Networks", *IEEE Transactions on Vehicular Technology*, vol. 61, issue 9, pp. 4129-4141, Nov. 2012
30. Ispas, A.; Dörpinghaus, M.; Ascheid, G.; Zemen, T., "Characterization of Non-stationary Channels Using Mismatched Wiener Filtering", *IEEE Transactions on Signal Processing*, vol. 61, issue 2, pp. 274-288, Jan. 2013
31. Castrillon, J.; Leupers, R.; Ascheid, G., "MAPS: Mapping Concurrent Dataflow Applications to Heterogeneous MPSoCs", *IEEE Transactions on Industrial Informatics*, vol. 9, issue 1, pp. 527-545, Feb. 2013
32. Dartmann, G.; Gong, X.; Afzal, W.; Ascheid, G., "On the Duality of the Max-Min Beamforming Problem With Per-Antenna and Per-Antenna-Array Power Constraints", *IEEE Transactions on Vehicular Technology*, vol. 62, issue 2, pp. 274-288, Feb. 2013
33. Gong, X.; Ispas, A.; Dartmann, G.; Ascheid, G., "Power Allocation and Performance Analysis in Spectrum Sharing Systems with Statistical CSI", *IEEE Transactions on Wireless Communications*, vol. 12, issue 4, pp. 1819-1831, Apr. 2013
34. Tong Peng; de Lamare, P.C.; Schmeink, A., "Adaptive Distributed Space-Time Coding Based on Adjustable Code Matrices for Cooperative MIMO Relaying Systems, *IEEE Transactions on Communications*, vol. 61, issue 7, pp. 1-12, May 2013
35. Bommès, D.; Campen, M.; Ebke, H.-C.; Alliez, P.; Kobbelt, L., "Integer-grid Maps for Reliable Quad Meshing", *ACM Transactions on Graphics (SIGGRAPH 2013)*, vol. 32, issue 4, July 2013
36. Grüner, S.; Radmacher, F.G.; Thomas, W., „Connectivity Games over Dynamic Networks“, *Theoretical Computer Science*, vol. 493, pp. 46-65, July 2013
37. Reinbacher, T.; Brauer, J.; Horauer, M.; Steininger, A.; Kowalewski, S., "Runtime Verification of Microcontroller Binary Code", *Science of Computer Programming*, vol. 80, Elsevier, pp. 109-129, Feb. 2014

38. Breddermann, T.; Eschbach, B.; Vary, P., "On the Design of Hybrid Automatic Repeat Request Schemes with Unreliable Feedback", *IEEE Transactions on Communications*, vol. 62, issue 2, pp. 758-768, Feb. 2014
39. Alirezaei, G.; Reyer, M.; Mathar, R.; "Optimum Power Allocation in Sensor Networks for Passive Radar Applications", *IEEE Transactions on Wireless Communications*, vol. 13, issue 6, pp. 3222-3231, June 2014
40. de Vries, J.P.; Simic, L.; Achtzehn, A.; Petrova, M.; Mähönen, P., "The Wi-Fi Congestion 'Crisis': Regulatory Criteria for Assessing Spectrum Congestion Claims", *Journal of Telecommunications Policy* vol. 38, issues 8-9, pp. 838-850, Sept. 2014
41. Hoefler, M.; Kesselheim, T.; Vöcking, B., "Approximation Algorithms for Secondary Spectrum Auctions", *ACM Transactions on Internet Technology (TOIT)*, vol. 14, issue 2-3, Article No. 16, Oct. 2014
42. Kovachev, D.; Nicolaescu, P.; Klamma, R.; "Mobile Real-Time Collaboration for Semantic Multimedia", *Journal of Mobile Networks and Applications*, vol. 19, issue 5, pp. 635-648, Oct. 2014
43. Jarke, M.; Jeusfeld, M.A.; Quix, C., "Data-centric intelligent information integration - from concepts to automation", *Journal of Intelligent Information Systems*, vol. 43, issue 3, pp. 437-462, Dec. 2014
44. Achtzehn, A.; Simic, L.; Petrova, M.; Mähönen, P., "Feasibility of Secondary Networks: Analysis Methodology and Quantitative Study of Cellular and Wi-Fi-like TVWS Deployments", *IEEE Transactions on Mobile Computing*, vol. 14, issue 2, pp. 373-386, Feb. 2015
45. Aref, A.F.; Hone, T.M.; Negra, R., "A Study of the Impact of Delay Mismatch on Linearity of Outphasing Transmitters", *IEEE Transactions on Circuits and Systems I*, vol. 62, issue 1, pp.254–262, Jan. 2015
46. Punal, O.; Pereira, C.; Aguiar, A.; Gross, J., "Experimental Characterization and Modeling of RF Jamming Attacks on VANETs", *IEEE Transactions on Vehicular Technology*, vol. 64, issue 2, pp. 524-540, Feb. 2015
47. Egners, A.; Herrmann, P.; Meyer, U., "Multi-Operator Wireless Mesh Networks Secured by an All-Encompassing Security Architecture", *International Journal of Information Security*, vol. 14, issue 2, pp. 169-186, Apr. 2015
48. Weyand, T.; Leibe, B., "Visual Landmark Recognition from Internet Photo Collections: A Large-Scale Evaluation", *Computer Vision and Image Understanding*, vol. 135, pp. 1-15, June 2015

7.1.2 Conference publications

Below is a very short list referencing five conference papers, selected either because they highlight the interdisciplinary bridge UMIC created taking theoretical computer science and electrical engineering as example (1, 4) or because they refer to IC design research which is primarily presented on conferences (2, 3).

1. Fischer, S.; Petrova, M.; Mähönen, P.; Vöcking, B., „Distributed Load Balancing Algorithm for Adaptive Channel Allocation for Cognitive Radios“, *2nd International Conference on Cognitive Radio Oriented Wireless Networks and Communications (CrownCom 2007)*, 2007
2. Zimmermann, N.; Thiel, B.T.; Negra, R.; Heinen, S., “System Architecture of an RF-DAC Based Multistandard Transmitter”, *52nd IEEE International Midwest Symposium on Circuits and Systems (MWSCAS'09)*, pp. 248-251, Aug. 2009
3. Mohr, B.; Zimmermann, N.; Thiel, B.T.; Mueller, J.H.; Yifan Wang; Ye Zhang; Lemke, F.; Leys, R.; Schenk, S.; Bruening, U.; Negra, R.; Heinen, S., „An RFDAC Based Reconfigurable Multistandard Transmitter in 65nm CMOS“, *2012 IEEE Radio Frequency Integrated Circuits Symposium (RFIC)*, pp. 109-112, June 2012.
4. Odendahl, M.; Goens, A.; Leupers, R.; Ascheid, G.; Ries, B.; Vöcking, B., „Optimized Buffer Allocation in Multicore Platforms“, *Design, Automation and Test in Europe Conference and Exhibition (DATE)*, 2014

7.2 Additional achievements

1. **ERC Advanced Grant 2013 “Across”**

Leif Kobbelt

2. **ERC Starting Grant 2012, “CV-Super”**

Bastian Leibe

3. **Evaluation of Electrical Engineering Faculties by Wissenschaftsrat**

In July 2011 the German Wissenschaftsrat published the results of its evaluation of German faculties/research centres for electrical engineering. EE of RWTH ranked first. In particular, Information and Communication Technology research quality of EE was the sole ranked “outstanding” out of 38 which were evaluated.

4. **Professorships for UMIC Doctoral and Postdoctoral Researchers, e.g.**

Jeronimo Castrillon, Associate Professor, TU Dresden, Germany

Marc Spaniol, Associate Professor, University of Caen, France

5. **Successful Proposals for DFG Priority Programmes**

Wireless 100 Gb/s and beyond, Co-Coordinator Gerd Ascheid

Compressed Sensing in Information Processing, Co-Coordinator Rudolf Mathar

6. **Top 10 of the worldwide most cited authors in Computer Graphics,**

Leif Kobbelt, 2011

7. **Gottfried-Wilhelm-Leibniz Prize 2014**

Leif Kobbelt

8. **IEEE Fellow**

Stefan Heinen, 2007, RF Design

Peter Vary, 2009, Speech Processing

9. **GI Fellow**

Otto Spaniol, 2008

Matthias Jarke, 2012

Wolfgang Thomas 2014

10. **Fellow of the ACM**

Matthias Jarke, 2013

11. **Eurographics Fellow**

Leif Kobbelt, 2008, Computer Graphics

12. **DFG Matheon Research Center**, Guest Professor,

Leif Kobbelt, 2009, Computer Graphics

13. **NRW Academy of Sciences and Arts**, Member,

Rudolf Mathar, 2011, Communication Theory

14. **German National Academy of Science and Engineering** (acatech), Member,

Klaus Wehrle, 2010

15. **Young Academy, North Rhine-Westphalian Academy of Sciences**, Member,
Anke Schmeink, 2009
16. **Dr. h.c., École Normale Supérieure de Cachan**
Member, European Academy of Sciences
Wolfgang Thomas
17. **Emmy Award**, 2009, Co-Chair, MPEG Video Subgroup
Eduard Rhein Award, 2010, Video conferencing
Jens-Rainer Ohm
18. **EWE Helene-Lange-Award** for young scientist, Anke Schmeink, 2009
19. **Conference Best Paper Awards**
24, UMIC researchers, 10/2006-10/2014
20. **EEEFOM Innovationspreis 2009**
Zimmermann, Heinen, Negra et al., 2009, RF Design
21. **Best demonstrator award**
IEEE DySPAN'11, Mähönen et al., 2011, Cognitive Radios
22. **External Dissertation Awards**, more than 10, e.g.
 - E-Plus Dissertation Award 2007, Anke Schmeink (Rudolf Mathar)
 - VDE Dissertation Award 2008, Torsten Clevorn (Peter Vary)
 - GI-BTW Dissertation Award 2009, Ira Assent (Thomas Seidl)
23. **External Master Student Awards**, e.g.
 - First Hugo Geiger Award for Best Master Thesis in Fraunhofer,
G. Hackenberg (Matthias Jarke), 2011, 3D Gesture Recognition
 - GI-BTW Student Award, S. Fries (Thomas Seidl), 2009, Anytime Stream
24. **Standardization and Pre-Standardization Contributions**
Participation into different working groups in following standardization bodies IETF (incl. RFC level work), IEEE (esp. 802 and SCC41/P1900 groups), ETSI, and ISO (MPEG-4). Active participation and support in the pre-standardization and industry harmonization groups such as NGMN and WinF (former SDR Forum).
25. **Renowned Conferences attracted to Aachen by UMIC Researchers, e.g.**
 - GeMiC 2014 Co-organiser: Renato Negra, Dirk Heberling
 - Prime 2012, Stefan Heinen, 2012, General Chair
 - IEEE DySPAN 2011, Petri Mähönen, Co-General Chair,
Marina Petrova, TPC Chair, 2011
 - 6th International Symposium on Trustworthy Global Computing (TGC); 22nd International Conference on Concurrency Theory (CONCUR); 8th International Conference on Quantitative Evaluation of Systems (QEST); Joost-Pieter Katoen, 2011, General Chair

- IEEE 8th Intern. Conference on Peer-to-Peer-Computing, Klaus Wehrle, 2008, General Chair
- IEEE 8th Intern. Forum on Application Specific Multi-Processor SoC, MPSoC Forum, Rainer Leupers, Heinrich Meyr, 2008, General Chair

26. **External Conference Organisations (examples)**

- 12th-17th European Wireless Conference, Bernhard Walke, 2006-2011, Chair of Steering Committee, 6 different locations in Europe
- PIMRC 2007-2012, Petri Mähönen, Advisory Board
- IEEE DySPAN 2009-2012, Petri Mähönen, Steering Board
- 12th ACM Conference Mobile HCI, Matthias Jarke, 2009, Program Co-Chair, Bonn
- 15th Intern. Conference of Tools and Algorithms for the Analysis and Construction of Systems (TACAS 2009), Stefan Kowalewski, 2009, Co-chair, York
- 3rd IEEE Intl. Conf. Ubiquitous Media Computing (UbiMedia), Ralf Klamma, Programme Chair 2010, China
- 33rd International Conference on Conceptual Modelling (ER14), Atlanta Georgia, Programme Co-Chair, 2014

27. **8 Patents Filed by UMIC Junior Professor**

- The research of Renato Negra led to filing of 8 patents

7.3 PIs and other participating researchers

7.3.1 Principal investigators

The principle investigators of the UMIC cluster are listed in Table 7-1. Three principle investigators retired during the first funding phase, one PI retired in the second funding phase and five PIs were added.

Table 7-1: Principal investigators

	Title, first name, surname	Institute	Re-search area(s)
1	Prof. Dr.-Ing. Gerd Ascheid	Integrated Signal Processing Systems	A, C
2	Prof. Dr.-Ing. Stefan Heinen	Analog Integrated Circuits	C, A
3	Prof. Dr. rer. pol. Matthias Jarke	Information Systems and Database Technology	B, D
4	Prof. Dr. ir. Joost-Pieter Katoen ²	Software Modelling and Verification	D
5	Prof. Dr. rer. nat. Leif Kobbelt	Computer Graphics and Multimedia	B
6	Prof. Dr.-Ing. Stefan Kowalewski	Embedded Software	D, B, C
7	Prof. Dr. rer. nat. Rainer Leupers ²	Software for Systems on Silicon	C, B
8	Prof. Petri Mähönen, Ph.D.	Networked Systems	A,C
9	Prof. Dr. rer. nat. Rudolf Mathar	Theoretical Information Technology	A,D
10	Prof. Dr. sc. techn. Heinrich Meyr ¹	Integrated Signal Processing Systems	A, C, D
11	Prof. Dr.-Ing. Tobias Noll	Electrical Eng. and Computer Systems	C, D
12	Prof. Dr. Ing. Jens-Rainer Ohm ²	Communication Engineering	B,C
13	Prof. Dr. rer. nat. Otto Spaniol ¹	Communication and Distributed Systems	B,D
14	Prof. Dr. rer. nat. Wolfgang Thomas	Theory of Discrete Systems	D
15	Prof. Dr.-Ing. Peter Vary	Communication Systems	A,C
16	Prof. Dr. rer. nat. Berthold Vöcking ²	Algorithms and Complexity	D
17	Prof. Dr.-Ing. Bernhard Walke ¹	Communication Networks	A,B
18	Prof. Dr.-Ing. Klaus Wehrle ²	Communication & Distributed Systems	A,B,D

¹ PIs who retired during the funding period

² PIs added during the funding period

The principal investigators Heinrich Meyr (in 2006) and Bernhard Walke (in 2007) retired in the beginning of the first funding period. Heinrich Meyr stayed in an active role in UMIC by continuing research projects and by acting as internal scientific advisors. Their successors Gerd Ascheid (for Heinrich Meyr) and Petri Mähönen (for Bernhard Walke) on the corresponding chairs were already PIs in the first period. The PI Otto Spaniol retired in 2010, his successor Klaus Wehrle already worked as participating researcher and replaced him as Steering Committee member.

Klaus Wehrle is also one of the new PIs. In the second phase Wolfgang Thomas retired but continued to contribute as senior researcher and internal scientific advisor. Since in the digital part of RA-C over time a stronger focus was put on system level design and tools, Rainer Leupers was added as PI in this field. Jens Rainer Ohm (Image and Video Coding) and Joost-Pieter Katoen (Software Modelling and Verification) had already contributed significantly before they were added as PIs and subsequently became key members of the team with highly relevant expertise.

7.3.2 Junior professors and junior research group leaders

Six junior professor positions were envisaged in the first period proposal (see also section 3.1, Table 3-1). Since the university reserved the required positions immediately the recruiting process was very effective. The fixed salary level in principle speeds up the process but can also be an obstacle as its low level is a competitive disadvantage on an international scale. Nevertheless, because of the attractiveness of the centre research environment, we were able to recruit high potential young researchers also from renowned international universities like e.g. ETH Zurich. All positions but one were filled by external applicants. For two positions (MPSoC Architectures and Mobile Embedded Data Management) there were no suitable applicants for the junior professorships. Since in MPSoC Architectures it was an issue of research field match, a second recruiting round was started after one year (to address new potential applicants) and lead to successful hiring of an applicant from industry. In the other case, it was an issue of inadequate qualification of the applicants for a junior professorship. Since there were high potential applicants for the Mobile Multimedia Processing postdoc position, which was recruited in parallel, the employment levels were exchanged, thus, flexibly solving both issues. The recruitment process for the successor of Bernhard Walke, who was expected to mentor the junior professor for Self-Organized Networks, unexpectedly required an excessive time period (three recruitment rounds). Therefore, the recruitment process for the sixth junior professor was delayed until 2011 but finally was closed successfully with the hiring of a highly qualified female applicant. As mentioned earlier, five of the junior professors are now on tenured professor positions.

7.3.3 Participating researchers at RWTH Aachen University

Further participating researchers can be mainly grouped into two categories: junior colleagues, in particular, professors hired by the university after funding start and professors from other faculties contributing to the interdisciplinary research of UMIC. The first category includes most notably the IT-Security professor, Ulrike Meyer, funded in the first funding phase by the UMIC centre and subsequently by the university. Other professors in this category are Thomas Seidl, Dirk Heberling and Bernhard Rumpe. Participating researchers who have extended the interdisciplinary re-

search are Michael Jansen (History of City Architecture), Jan Borchers (Human-Computer Interaction, HCI), Steffen Leonhardt (Medical Information Technology) and Thomas Gries (Textile Technology and Mechanical Engineering) in the field of smart textiles.

7.3.4 Participating researchers at other universities

Two research groups were integrated into the cluster research through research contracts. The first group is the Electronic Measurement Research Lab of TU Ilmenau headed by Prof. Reiner Thomä. After in-depth study of channel sounding requirements the UMIC Steering Committee agreed that it would not be efficient to build up own expertise and equipment in the field of channel measurements and channel sounding. Rather, through a collaboration a larger amount of measurement results was available and missing measurements could be performed in short time by the experienced team of TU Ilmenau.

The second research group was the Microelectronic Systems Design Group of TU Kaiserslautern headed by Prof. Norbert Wehn. In this case, it was the strong expertise in high data rate iterative decoding both on algorithmic level and on implementation level which was considered as extremely important to complement the physical layer implementation expertise at RWTH Aachen University.

7.4 Doctoral researchers

Table 7-2: Doctoral researchers – completed and ongoing theses

	Doctoral theses completed within the centre ¹⁾	Thereof: (partially [$\geq 50\%$]) financed by the centre	On-going doctoral theses after expiry of centre's funding
Total (number)	97	71	79
Thereof: Females (%)	13.4	12.7	16.5
Origin ²⁾			
Number and %			
Germany	77 / 79.4%	57 / 80.3%	69 / 87.3%
European ./ Germany	7 / 7.2%	4 / 5.6%	1 / 1.3%
Non-European	13 / 13.4%	10 / 14.1%	9 / 11.4%

1) Completed during the centre's total funding duration (November 1, 2006 to Oktober 31, 2014); completion is defined as the date of the final doctoral exam, e.g. "Disputatio" or "Rigorosum".

2) Refers to the last position held prior to joining the centre.

A few comments should be made about the numbers in Table 7-2. The percentage of students with origin Germany is rather high. This is due to two reasons. First, RWTH Aachen University has a very high number of students (currently more than 6,000 students in EE and CS). Therefore, there is a quite large pool of excellent students finishing their Master degree each year. Second, RWTH Aachen University offers international Master courses taught in English to which only top international students are admitted. These courses attract students primarily from Asia (e.g. India and China), Africa but also from other European countries. A significant number of doctoral researchers are graduates from these courses. Since they completed their Master of Science at RWTH Aachen University, they have to be counted under "Origin Germany" according to the guidelines.

The funding of the doctoral theses ongoing after expiry of the centre's funding is ensured. The activities of the UMIC research centre have strengthened the already substantial amount of third party funding of the main involved departments (CS and EE). In addition, the UMIC research centre has reserved funds to solve any financial issues should they occur in individual cases.

UMIC Research Centre

RWTH Aachen University

Mies-van-der-Rohe-Str. 15

52074 Aachen

www.unic.rwth-aachen.de